

# KitchenAid®

## 12 CUP FOOD PROCESSORS

INSTRUCTIONS AND RECIPES

MODELS KFPW760 & KFPM770



1-800-541-6390  
Details Inside



FOR THE WAY IT'S MADE.™

# Hassle-Free Replacement Warranty

---



We're so confident the quality of our products meets the exacting standards of KitchenAid that, if your Food Processor should fail within the first year of ownership, KitchenAid will arrange to deliver an identical or comparable replacement to your door free of charge and arrange to have your original Food Processor returned to us. Your replacement unit will also be covered by our one year full warranty. Please follow these instructions to receive this quality service.

**If You Reside In The 50 United States** and your KitchenAid® Food Processor should fail within the first year of ownership, simply call our toll-free Customer Satisfaction Center at **1-800-541-6390** Monday through Friday, 8 a.m. to 8 p.m. (Eastern Time), or Saturday, 10 a.m. to 5 p.m. Give the consultant your complete shipping address. (No P.O. Box Numbers, please.)

When you receive your replacement Food Processor, use the carton and packing materials to pack-up your original Food Processor. In the carton, include your name and address on a sheet of paper along with a copy of the proof of purchase (register receipt, credit card charge slip, etc.).

For a detailed explanation of warranty terms and conditions, including how to arrange for service outside the United States, see pages 57 and 58.

## Proof of Purchase & Product Registration

---

Always keep a copy of the sales receipt showing the date of purchase of your Food Processor. Proof of purchase will assure you of in-warranty service.

Before you use your Food Processor, please fill out and mail your product registration card packed with the unit. This card will enable us to contact you in the

unlikely event of a product safety notification and assist us in complying with the provisions of the Consumer Product Safety Act. This card does not verify your warranty.

Please complete the following for your personal records:

Model Number \_\_\_\_\_

Serial Number \_\_\_\_\_

Date Purchased \_\_\_\_\_

Store Name \_\_\_\_\_

# Table of Contents

---

## INTRODUCTION

Hassle-Free Replacement Warranty.....	Inside Front Cover
Product Registration Card .....	Inside Front Cover
Food Processor Safety .....	3
Important Safeguards .....	4
Electrical Requirements.....	5

## FEATURES AND OPERATION

Food Processor Features .....	6
Preparing the Food Processor for Use	
Before First Use .....	8
Work Bowl Assembly .....	8
Multipurpose Blade & Dough Blade Assembly .....	9
Slicing & Shredding Disc Assembly .....	9
Mini Bowl Assembly.....	10
Chef's Bowl Assembly .....	10
Egg Whip Assembly & Use.....	11
Citrus Press Assembly & Use.....	11
Using the Food Processor	
Before Use .....	13
Food Pusher Interlock .....	13
Maximum Liquid Level .....	13
Turning the Food Processor On and Off .....	13
Using the Pulse Control .....	14
2-Piece Food Pusher .....	14
Disassembling the Food Processor .....	14

## CARE AND CLEANING

Cleaning the Food Processor.....	16
Troubleshooting .....	17

Continued on next page

# Table of Contents

---

## FOOD PROCESSING TIPS

Using the Multipurpose Blade.....	18
Using a Slicing or Shredding Disc .....	19
Using the Dough Blade.....	20
Using the Egg Whip .....	20
Helpful Hints .....	21

## RECIPES

Appetizers .....	23
Salads and Dressings .....	28
Soups and Sandwiches.....	32
Vegetables and Side Dishes .....	37
Main Dishes.....	41
Breads .....	46
Desserts.....	51

## WARRANTY AND SERVICE INFORMATION

Warranty for the 50 United States and District of Columbia .....	57
Warranty For Puerto Rico .....	58
Arranging for Service after the Warranty Expires.....	58
Arranging for Service Outside the 50 United States and Puerto Rico.....	58
Ordering Accessories and Replacement Parts .....	59

# Food Processor Safety

## **Your safety and the safety of others are very important.**

We have provided many important safety messages in this manual and on your appliance. Always read and obey all safety messages.



This is the safety alert symbol.

This symbol alerts you to potential hazards that can kill or hurt you and others.

All safety messages will follow the safety alert symbol and either the word "DANGER" or "WARNING." These words mean:

 **DANGER**

**You can be killed or seriously injured if you don't immediately follow instructions.**

 **WARNING**

**You can be killed or seriously injured if you don't follow instructions.**

All safety messages will tell you what the potential hazard is, tell you how to reduce the chance of injury, and tell you what can happen if the instructions are not followed.

# IMPORTANT SAFEGUARDS

---

When using electrical appliances, basic safety precautions should always be followed, including the following:

1. Read all instructions.
2. To protect against risk of electrical shock do not put Food Processor in water or other liquid.
3. Close supervision is necessary when any appliance is used by or near children.
4. Unplug from the outlet when not in use, before putting on or taking off parts, and before cleaning.
5. Avoid contacting moving parts.
6. Do not operate any appliance with a damaged cord or plug, or after the appliance malfunctions, or is dropped or damaged in any manner. Return appliance to the nearest Authorized Service Facility for examination, repair, or electrical or mechanical adjustment.
7. The use of attachments not recommended or sold by the manufacturer may cause fire, electric shock or injury.
8. Do not use outdoors.
9. Do not let cord hang over edge of table or counter.
10. Keep hands and utensils away from moving blades or discs while processing food to reduce the risk of severe injury to persons or damage to the Food Processor. A scraper may be used but must be used only when the Food Processor is not running.
11. Blades are sharp. Handle carefully.
12. To reduce the risk of injury, never place cutting blade or discs on base without first putting bowl properly in place.
13. Be certain cover is securely locked in place before operating appliance.
14. Never feed food by hand. Always use the food pusher.
15. Do not attempt to defeat the cover interlock mechanism.
16. This product is designed for household use only.

## SAVE THESE INSTRUCTIONS

# Electrical Requirements

---

## Model KFPM770:

Volts: 120 V.A.C. only  
Hertz: 60 Hz

 **WARNING**



**Electrical Shock Hazard**

**Plug into a grounded 3 prong outlet.**

**Do not remove ground prong.**

**Do not use an adapter.**

**Do not use an extension cord.**

**Failure to follow these instructions can result in death, fire or electrical shock.**

## Model KFPW760:

Volts: 120 V.A.C. only  
Hertz: 60 Hz

**NOTE:** Model KFPW760 has a polarized plug (one blade is wider than the other). To reduce the risk of electrical shock, this plug will fit in a polarized outlet only one way. If the plug does not fit fully in the outlet, reverse the plug. If it still does not fit, contact a qualified electrician. Do not modify the plug in any way.

Do not use an extension cord. If the power supply cord is too short, have a qualified electrician or serviceman install an outlet near the appliance.

**NOTE:** Model KFPM770 has a 3 prong grounded plug. To reduce the risk of electrical shock, this plug will fit in an outlet only one way. If the plug does not fit in the outlet, contact a qualified electrician. Do not modify the plug in any way.

Do not use an extension cord. If the power supply cord is too short, have a qualified electrician or serviceman install an outlet near the appliance.

# Food Processor Features





# Food Processor Features

---

## **Work Bowl Cover with Ultra Wide Mouth™ Feed Tube**

One of the industry's largest, the Ultra Wide Mouth™ feed tube accommodates large items – like tomatoes, cucumbers, and potatoes – with a minimum of sectioning or slicing.

## **2-Piece Food Pusher**

For smaller items, remove the small pusher from the central tube in the large pusher. The small pusher and feed tube make it easy to process herbs, nuts, single carrots and celery. The small pusher can also be used as a convenient 4 oz. measuring cup.

## **12-Cup Work Bowl**

The tough polycarbonate bowl provides capacity for large jobs.

## **Chef's Bowl**

Place the 10-cup Chef's Bowl inside the Work Bowl, and slice or shred a food item while keeping the Work Bowl clean for another ingredient.

## **Mini Bowl and Mini Blade**

4-cup bowl and stainless steel blade are perfect for small chopping and mixing jobs.

## **Fine (2 mm) Slicing Disc**

Disc produces approximately 1/6-inch slices of most foods, from delicate strawberries to partially frozen meats.

## **Medium (4 mm) Slicing Disc**

Disc produces approximately 1/8-inch slices of most foods.

## **Medium (4 mm) Shredding Disc**

Disc produces approximately 1/8-inch shreds of most firm fruits, vegetables, and cheese.

## **Disc Stem**

Stem fits over the power shaft on the base and into the bottom of a slicing or shredding disc.

## **Stainless Steel Multipurpose Blade**

Versatile blade chops, minces, blends, mixes, and emulsifies in a matter of seconds.

## **Dough Blade**

The dough blade is specially designed for mixing and kneading yeast dough.

## **Egg Whip**

The egg whip will quickly whip cream and egg whites for meringues, mousses, soufflés, and desserts.

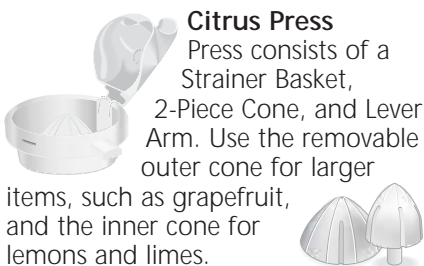

## **Citrus Press**

Press consists of a Strainer Basket, 2-Piece Cone, and Lever Arm. Use the removable outer cone for larger

items, such as grapefruit, and the inner cone for lemons and limes.

## **Heavy-Duty Base**

The base features the off, on, and pulse buttons along with the power shaft, which rotates the blades and discs.

## **Spatula/Cleaning Tool**

Special shape facilitates food removal from bowls, discs, and blades.

## **Chef's Accessory Case**

Stylish and durable slim-line case organizes and protects blades, discs, and accessories.



# Preparing the Food Processor for Use

## WARNING

### Cut Hazard

Handle blades carefully.

Failure to do so can result in cuts.

### Before First Use

Before using your Food Processor for the first time, wash the work bowl, work bowl cover, chef's bowl, mini bowl, feed tube pusher, discs, and blades either by hand or in the dishwasher (see "Cleaning the Food Processor" on page 16).

### Work Bowl Assembly

1. Place the Food Processor base on a dry, level countertop with the controls facing forward. Do not plug in the unit until it is completely assembled.
2. With the handle just to the left of center, place the work bowl on the base, fitting the center opening over the power shaft.
3. Grasp the work bowl handle and turn the bowl to the right until it locks into position.



4. Insert the desired accessory into the work bowl. See pages 9–12 for accessory instructions.
5. Place the work bowl cover on the work bowl with the feed tube just to the left of the work bowl handle. Grasp the feed tube and turn the cover to the right until it locks into place.



**NOTE:** Do not attach the cover to the work bowl before the work bowl is locked on the base. Damage to the work bowl may result.

6. Fit the 2-piece food pusher into the feed tube.



# Preparing the Food Processor for Use

## **WARNING**



### **Electrical Shock Hazard**

**Plug into a grounded 3 prong outlet.**

**Do not remove ground prong.**

**Do not use an adapter.**

**Do not use an extension cord.**

**Failure to follow these instructions can result in death, fire or electrical shock.**

7. Plug into a proper electrical outlet (see "Electrical Requirements" on page 5).

**NOTE:** Your Food Processor will not operate unless the work bowl and work bowl cover are properly locked on the base, and the pusher is inserted to the maximum fill line on the feed tube.

Do not remove the work bowl from the base without first removing the work bowl cover. Damage to the work bowl may result.

## **WARNING**

### **Cut Hazard**

**Handle blades carefully.**

**Failure to do so can result in cuts.**

### **Multipurpose Blade and Dough Blade Assembly**

Place the blade on the power shaft. Rotate the blade so it falls into place on the shaft.



### **Slicing and Shredding Disc Assembly**

1. Place the disc stem on the power shaft.



Continued on next page

# Preparing the Food Processor for Use

## WARNING

### Cut Hazard

Handle blades carefully.

Failure to do so can result in cuts.

2. Fit the disc over the metal pin on the disc stem, then rotate the disc until it falls fully onto the stem.



### Mini Bowl Assembly

1. Place the mini bowl inside the work bowl over the power shaft. Rotate the mini bowl until it falls into place. When properly seated in the work bowl, the mini bowl cannot be rotated.



2. Fit the mini blade on the power shaft. It may be necessary to rotate the blade until it falls into place.



The mini bowl can also be placed in the chef's bowl in a similar manner.

3. To remove the mini bowl after processing, lift the bowl using the two finger grips located along the top edge of the bowl.



### Chef's Bowl Assembly

Place the chef's bowl inside the work bowl over the power shaft. Rotate the chef's bowl until it falls into place. When properly seated in the work bowl, the chef's bowl cannot be rotated.

The chef's bowl can only be used with the slicing and shredding discs – the multipurpose blade cannot be used. To remove the chef's bowl after processing, lift the bowl using the two finger grips located along the top edge of the bowl.

# Preparing the Food Processor for Use

## Egg Whip Assembly and Use

The egg whip is designed to whip egg whites or heavy cream to create toppings or soft meringues. For the best results, at least 1 cup of heavy cream or 3 egg whites should be whipped at a time. Whipping smaller quantities may not result in maximum volume.

### To assemble:

The egg whip consists of 4 pieces – the egg whip stem, stem cover, whip paddle, and cap.

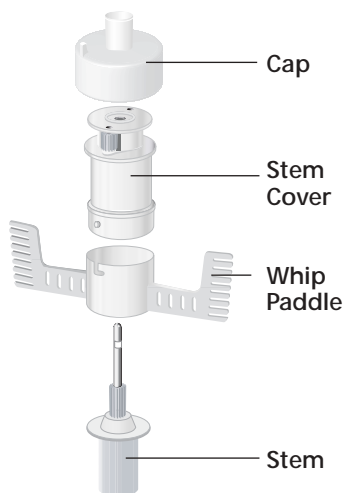

1. Place the egg-whip stem on the power shaft. Slowly turn the stem until it drops fully onto the shaft.
2. Align the L-shaped notch on the whip paddle with the small post on the stem cover, and slide the paddle onto the cover. Turn slightly to lock paddle.
3. Fit the stem cover and paddle over the egg whip stem. Push downward to engage the ridges of the stem with the gears of the paddle.
4. Fit the egg whip cap over the egg whip stem. Push downward to lock it into place.

5. Place the work bowl cover on the work bowl with the feed tube just to the left of the handle. Make sure the center pin of the egg whip fits into the center opening of the cover. Grasp the feed tube and turn the cover to the right to lock it into place. Insert the pusher into the feed tube. The egg whip is now ready to operate.
6. Press the On Button and whip ingredients to the desired texture and volume. Press the Off Button when finished.

### To disassemble:

1. Unplug the base from the electrical outlet. Remove the work bowl cover with a clockwise turn.
2. Lift the egg whip assembly off the power shaft. Remove whipped ingredients from the work bowl.
3. Pull the cap from the egg whip assembly. Push downward on the stem pin to remove stem from the stem cover. Turn the egg whip paddle to unlock, and slide the paddle from the stem cover.

## Citrus Press Assembly and Use

1. Position and lock the work bowl on the base.
2. Place the strainer basket in the bowl with the locking clip to the left of the work bowl handle.
3. Turn the basket counter-clockwise until the clip locks into the handle.



Continued on next page

## Preparing the Food Processor for Use

---

4. The 2-piece cone offers two sizes; choose the right size for the fruit you are juicing. Use the outer cone for grapefruit, oranges and other large fruits. Remove the outer cone to reveal a smaller inner cone that's perfect for lemons and limes.
5. Open the lid and place the cone inside the strainer basket over the power shaft. It may be necessary to rotate the cone until it falls into place.



6. Halve the fruit to be juiced.
7. Place fruit half on cone.
8. Close the lid of the strainer basket. Hold the lever arm down firmly with an open palm to maintain even pressure. Operate the citrus press only when the lever arm is in the down position, holding the fruit on the cone.

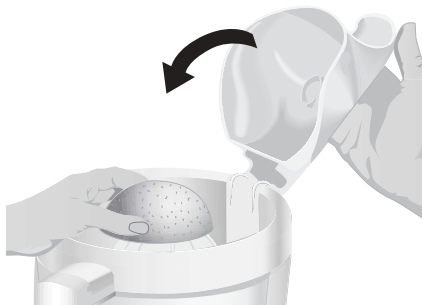

**NOTE:** Use of the citrus press without the clip-on lever arm is not recommended. If you do use it without the lever arm, remove the lever arm from the basket (see Step 13).

9. Operate the citrus press by pressing the On Button or the Pulse Button.
  10. When juice is fully extracted, Press the Off Button.
- NOTE:** Do not exceed the maximum liquid level line on the work bowl, or juice will leak from the bowl.
11. Unlock the strainer basket by turning it clockwise. Remove juiced fruit, cone, and strainer basket from the work bowl.
  12. Remove the work bowl from Food Processor and pour juice into desired container.
  13. To detach the clip-on lever arm from the strainer basket for thorough cleaning, pull the clip at the bottom of the basket away from the basket side and remove the lever-arm from the basket.
  14. When reattaching the lever arm to the strainer basket, make sure the tabs on the clip snap securely into a pair of holes in the bottom of the basket.

# Using the Food Processor

## WARNING



### Rotating Blade Hazard

**Always use food pusher.**

**Keep fingers out of openings.**

**Keep away from children.**

**Failure to do so can result in amputation or cuts.**

### Before Use

Before operating the Food Processor, be sure the work bowl, blades, and work bowl cover are properly assembled on the Food Processor base (see “Preparing the Food Processor for Use” starting on page 8).

### Food Pusher Interlock

The food pusher is part of the safety interlock system. The Food Processor will not run unless the pusher is inserted to the maximum fill line on the feed tube.

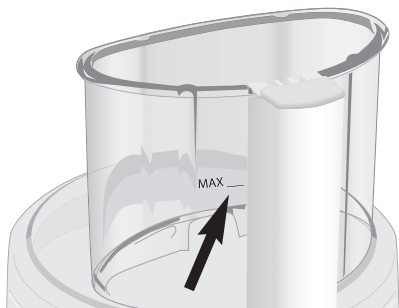

### Maximum Liquid Level

This line on the work bowl indicates the maximum level of liquid that can be processed by the Food Processor.



### Turning the Food Processor On and Off

1. To turn on the Food Processor, press the On Button. The unit will run continuously and the indicator light will glow.



2. To stop the Food Processor, press the Off Button. The indicator light will go out and an automatic brake will stop the action of the blade or disk within seconds.
3. Wait until the blade or disk comes to a complete stop before removing the work bowl cover. Be sure to turn off the Food Processor before removing the work bowl cover, or before unplugging the unit.

**NOTE:** If the unit fails to operate, make sure the work bowl and cover are properly locked on the base, and the food pusher is inserted to the maximum fill line on the feed tube (see “Preparing the Food Processor for Use” starting on page 8).

# Using the Food Processor

## WARNING



### Rotating Blade Hazard

**Always use food pusher.**

**Keep fingers out of openings.**

**Keep away from children.**

**Failure to do so can result in amputation or cuts.**

## Using the Pulse Control

The pulse control allows precise control of the duration and frequency of processing. It's great for jobs which require a light touch. Just press and hold the Pulse Button to start processing, and release it to stop. The indicator light will glow each time the Pulse Button is pressed.

## The 2-Piece Food Pusher

To slice or shred small items, insert the 2-piece food pusher into the feed tube, then turn the small center pusher clockwise to unlock and remove. Use the center feed tube and pusher to process small or slender items, or to add liquid while the Food Processor is running. When not using the small feed tube, lock the small pusher into place by turning it counter-clockwise.

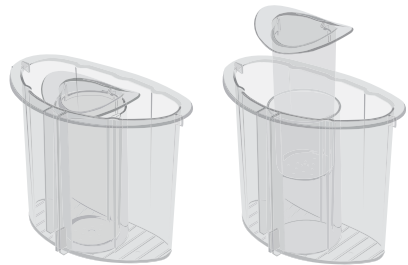

# Disassembling the Food Processor

## WARNING

### Cut Hazard

**Handle blades carefully.**

**Failure to do so can result in cuts.**

**NOTE:** If you have difficulty removing the pusher from the feed tube, it is likely that food particles have become lodged in the interlock system. To free the pusher, soak the work bowl cover in warm water or wash it in a dishwasher.

1. Turn the work bowl cover to the left and remove.





# Disassembling the Food Processor

2. If using a disc, remove it before removing the bowl. Place two fingers under each side of the disc and lift it straight up. Remove the disc stem.



3. If using the mini bowl or chef's bowl, grasp and remove the bowl using the finger grips located along the top edge of the bowl.



4. Turn the work bowl to the left to unlock it from the base. Lift to remove.



5. The multipurpose blade can be removed from the work bowl before the contents are emptied. The blade can also be held in place as you remove food: grasp the work bowl from the bottom and place one finger through the center opening to grip the blade shaft. Then remove food from the bowl and blade with a spatula.



# Cleaning the Food Processor



## WARNING

### Cut Hazard

**Handle blades carefully.**

**Failure to do so can result in cuts.**

1. Press the Off Button and unplug the Food Processor before cleaning.
2. Wipe the base and cord with a warm, sudsy cloth, and wipe clean with a damp cloth. Dry with a soft cloth. Do not use abrasive cleansers or scouring pads.
3. All the other parts of the Food Processor are dishwasher safe. Be sure to load them away from exposed heating elements in the dishwasher. If washing the Food Processor parts by hand, avoid the use of abrasive cleansers or scouring pads. They may scratch or cloud the work bowl and cover. Thoroughly dry all parts after washing.
4. To prevent damage to the interlock system, always store the work bowl and work bowl cover in the unlocked position when not in use.
5. Wrap the power cord around the work bowl. Secure the plug by clipping it to the cord.
6. Disassembled discs, shafts, and blades should be stored in the provided storage case, and in a location out of the reach of children.

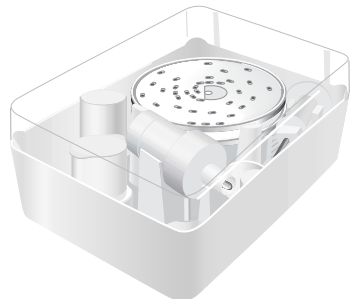

# Troubleshooting

---

- **If your Food Processor should fail to operate, check the following:**

- Make sure the work bowl and work bowl cover are properly locked on the base, and the food pusher is inserted to the maximum fill line on the feed tube.
- See if the power cord is plugged into a proper electrical outlet (see “Electrical Requirements” on page 5). If it is, unplug the Food Processor, then plug it into the same outlet again. If the Food Processor still does not work, check the fuse or circuit breaker on the electrical circuit the Food Processor is connected to and make sure the circuit is closed.

- **If the Food Processor shuts off while it is running:**

- The Food Processor may be overheated. If the motor exceeds a certain temperature, it will automatically shut off to prevent damage. This should be an extremely rare occurrence. If it happens, press the Off Button and wait 15 minutes for the Food Processor to cool before resuming. If the Food Processor still refuses to run, wait an additional 15 minutes for the Food Processor to cool.

- **If you have difficulty removing the food pusher from the feed tube:**

- Food particles are probably lodged in the interlock system. To free the pusher, soak the work bowl cover in warm water or wash it in a dishwasher.

If the problem cannot be corrected with the steps in this section, see the KitchenAid Warranty and Service section on pages 57-58. Do not return the Food Processor to the retailer – they do not provide service.

# Food Processing Tips

---



## USING THE MULTIPURPOSE BLADE

### **To chop fresh fruits or vegetables:**

Peel, core, and/or remove seeds. Cut food in 1 to 1½-inch pieces. Process food to desired size, using short pulses, 1 to 2 seconds each time. Scrape sides of bowl, if necessary.

### **To puree cooked fruits and vegetables (except potatoes):**

Add ¼ cup liquid from recipe per cup of food. Process food, using short pulses, until finely chopped. Then process continuously until reaching desired texture. Scrape sides of bowl, if necessary.

### **To prepare mashed potatoes:**

Insert chef's bowl into the work bowl. Using the shredding disc, shred hot, cooked potatoes. Remove the chef's bowl with potatoes. Place multipurpose blade in work bowl, and add shredded potatoes, softened butter, milk, and seasonings. Pulse 3 to 4 times, 2 to 3 seconds each time, until milk is absorbed and texture is smooth. Do not overprocess.

### **To chop dried (or sticky) fruits:**

The food should be cold. Add ¼ cup flour from recipe per ½ cup dried fruit. Process fruit, using short pulses, until reaching desired texture.

### **To finely chop citrus peel:**

With sharp knife, peel colored portion (without white membrane) from citrus. Cut peel in small strips. Process until finely chopped.

### **To mince garlic or to chop fresh herbs or small quantities of vegetables:**

With processor running, add food through the small feed tube. Process until chopped. For best results, make sure work bowl and herbs are very dry before chopping.

### **To chop nuts or make nut butters:**

Process up to 3 cups of nuts to desired texture, using short pulses, 1 to 2 seconds each time. For a coarser texture, process smaller batches, pulsing 1 or 2 times, 1 to 2 seconds each time. Pulse more often for finer texture. For nut butters, process continuously until smooth. Store in refrigerator.

### **To chop cooked or raw meat, poultry or seafood:**

The food should be very cold. Cut in 1-inch pieces. Process up to 1 pound at a time to desired size, using short pulses, 1 to 2 seconds each time. Scrape sides of bowl, if necessary.

### **To make bread, cookie, or cracker crumbs:**

Break food into 1½ to 2-inch pieces. Process until fine. For larger pieces, pulse 2 to 3 times, 1 to 2 seconds each time. Then process until fine.

### **To melt chocolate in a recipe:**

Combine chocolate and sugar from recipe in work bowl. Process until finely chopped. Heat liquid from recipe. With processor running, pour hot liquid through the small feed tube. Process until smooth.

# Food Processing Tips

## To grate hard cheeses, such as Parmesan and Romano:

Never attempt to process cheese that cannot be pierced with the tip of a sharp knife. You can use the multi-purpose blade to grate hard cheeses. Cut cheese in 1-inch pieces. Place in work bowl. Process, using short pulses, until coarsely chopped. Process continuously until finely grated. Pieces of cheese can also be added through the small feed tube while the processor is running.



### USING A SLICING OR SHREDDING DISC

**NOTE:** When cutting and packing food items in the Ultra Wide Mouth™ feed tube, do not exceed the maximum fill line. This will permit the pusher to engage the interlock and the unit to operate.

## To cut julienne, or match stick, strips of vegetables and fruits:

Cut food to fit feed tube horizontally. Position food horizontally in feed tube. Process, using even pressure to make plank-like slices. Re-stack slices and position vertically or horizontally in feed tube. Process, using even pressure.

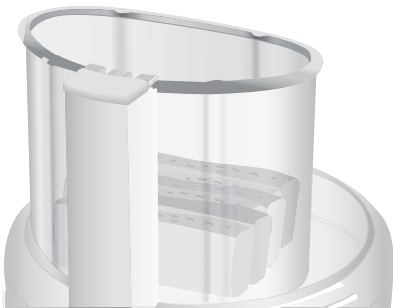

## To slice or shred fruits or vegetables that are long and relatively small in diameter, such as celery, carrots, and bananas:

Cut food to fit feed tube vertically or horizontally, and pack feed tube securely to keep food positioned properly. Process using even pressure. Or use the small feed tube in the two-piece food pusher. Position food vertically in the tube and use the small food pusher to process food.



## To slice or shred fruits and vegetables that are round, such as onions, apples, and green peppers:

Peel, core, and/or remove seeds. Cut in halves or quarters to fit feed tube. Position in feed tube. Process, using even pressure.

## To slice or shred fruits and vegetables that are small, such as strawberries, mushrooms, and radishes:

Position food vertically or horizontally in layers within the feed tube. Fill feed tube in order to keep food positioned properly, but do not exceed the maximum fill line. Process, using even pressure. Or use the small feed tube in the two-piece food pusher. Position food vertically in the tube and use the small food pusher to process food.

## To shred spinach and other leaves:

Stack leaves. Roll up and stand up in feed tube. Process, using even pressure.



# Food Processing Tips

---

## **To slice uncooked meat or poultry, such as stir-fry meats:**

Cut or roll food to fit feed tube. Wrap and freeze food until hard to the touch, 30 minutes to 2 hours, depending on thickness of food. Check to be sure you can still pierce food with the tip of a sharp knife. If not, allow to thaw slightly. Process, using even pressure.

## **To slice cooked meat or poultry, including salami, pepperoni, etc.:**

Food should be very cold. Cut in pieces to fit feed tube. Process food using firm, even pressure.

## **To shred firm and soft cheeses:**

Firm cheese should be very cold. For best results with soft cheeses, such as mozzarella, freeze 10 to 15 minutes before processing. Cut to fit feed tube. Process, using even pressure.



## **USING THE DOUGH BLADE**

The dough blade is specially designed for mixing and kneading yeast dough quickly and thoroughly. For the best results, do not knead recipes which use more than 2-3 cups of flour.



## **USING THE EGG WHIP**

### **To make soft egg white meringue:**

Place 3 egg whites and  $\frac{1}{4}$  teaspoon cream of tartar in work bowl fitted with egg whip. Process until foamy, about 30 to 45 seconds. With processor running, slowly add  $\frac{1}{2}$  cup sugar through the small feed tube. Process until stiff peaks form, about  $2\frac{1}{2}$  to 3 minutes. Stop processor as necessary to check texture of mixture.

### **To whip cream:**

Place heavy cream in work bowl fitted with egg whip. Process 30 seconds. With processor running, add 2 tablespoons powdered sugar through the small feed tube. Process just until soft peaks form, about 30 to 40 seconds. Stop processor as necessary to check texture of mixture. With processor running, add  $\frac{1}{2}$  teaspoon vanilla, if desired, through the small feed tube. Process just until mixed. Do not overprocess.

# Helpful Hints

---

1. When cutting and packing food items in the Ultra Wide Mouth™ feed tube, do not exceed the maximum fill line. This will permit the pusher to engage the interlock and the unit to operate.
  2. Never process any food that is so hard or firmly frozen that it cannot be pierced with the tip of a sharp knife. Hard food can cause damage to the blade or motor. If a piece of hard food, such as carrot, becomes wedged or stuck on the blade, stop the processor and remove the blade. Carefully remove food from the blade.
  3. Do not overfill work bowl or mini bowl. For thin mixtures, fill work bowl up to  $\frac{1}{2}$  to  $\frac{2}{3}$  full. For thicker mixtures, fill work bowl up to  $\frac{3}{4}$  full. For liquids, fill up to the maximum level as described on page 13. When chopping, the work bowl should be no more than  $\frac{1}{2}$  to  $\frac{1}{2}$  full. Use the mini bowl for up to 1 cup of liquid or  $\frac{1}{2}$  cup solids.
  4. Position slicing discs so the cutting surface is just to the right of the feed tube. This allows the blade a full rotation before contacting the food.
  5. To capitalize on the speed of the processor, drop ingredients to be chopped through the small feed tube while the processor is running.
  6. Different foods require varying degrees of pressure for best shredding and slicing results. In general, use light pressure for soft, delicate foods (strawberries, tomatoes, etc.), moderate pressure for medium foods (zucchini, potatoes, etc.), and firmer pressure for harder foods (carrots, apples, hard cheeses, partially frozen meats, etc.).
  7. Soft and medium-hard cheese may spread out or roll up on the shredding disc. To avoid this, shred only well-chilled cheese.
  8. Sometimes slender foods, such as carrots or celery, fall over in the feed tube, resulting in an uneven slice. To minimize this, cut food in several pieces and pack the feed tube with the food. For processing small or slender items, the small feed tube in the two piece food pusher will prove especially convenient.
- 
9. When preparing a cake or cookie batter or quick bread, use the multipurpose blade to cream fat and sugar first. Add dry ingredients last. Place nuts and fruit on top of flour mixture to prevent overchopping. Process nuts and fruits, using short pulses, until blended with other ingredients. Do not overprocess.
  10. When shredded or sliced food piles up on one side of the bowl, stop the processor and redistribute the food using a spatula.
  11. When food quantity reaches the bottom of a slicing or shredding disc, remove the food.
  12. A few larger pieces of food may remain on top of the disc after slicing or shredding. If desired, cut these by hand and add to mixture.
  13. Organize processing tasks to minimize bowl cleanup. Process dry or firm ingredients before liquid ingredients.
  14. To clean ingredients from the multipurpose blade easily, just empty the work bowl, replace the lid, and pulse 1 to 2 seconds to spin the blade clean.

## Helpful Hints

---

15. After removing the work bowl cover, place it upside down on the counter. This will help keep the counter clean.
16. To remove the contents of the work bowl without removing the multipurpose blade, grasp the work bowl from the bottom and place one finger through the center opening to hold the blade in place. Then remove food from the bowl and blade with a spatula.
17. Your Food Processor is not designed to perform the following functions:
  - grind coffee beans, grains, or hard spices
  - grind bones or other inedible parts of food
  - liquefy raw fruits or vegetables
  - slice hard-cooked eggs or unchilled meats.
18. If any plastic parts should discolor due to the types of food processed, clean them with lemon juice.

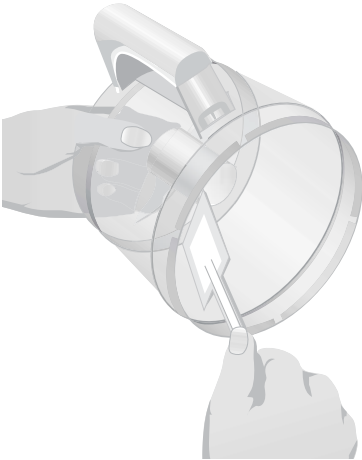



## Sausage-Stuffed Mushrooms

- 1 *bakery croissant or white bread slice, torn into pieces*
- 1 *shallot, cut into quarters*
- 1 *clove garlic*
- 15 *large (about 14 oz.) mushrooms, cleaned*
- 6 *ounces ground sausage*
- 1 *teaspoon Worcestershire sauce*
- ½ *teaspoon dry mustard*
- ¼ *teaspoon hot pepper sauce*
- 1 *cup shredded Cheddar cheese*
- 2 *tablespoons snipped fresh chives, if desired*

Position mini bowl and mini blade in work bowl. Add croissants. Process until finely crumbled, 10 to 20 seconds. Remove and set aside.

Position mini bowl and mini blade in work bowl. Add shallot and garlic. Process until finely chopped, 5 to 10 seconds. Remove stems from mushrooms; add ½ cup stems to shallot mixture in mini bowl. Pulse 3 to 4 times, about 1 second each time, or until chopped.

In medium skillet over medium heat, cook sausage until thoroughly heated and no longer pink. Drain. Add mushroom mixture; cook 2 to 4 minutes, or until tender, stirring often.

Exchange mini bowl and mini blade for multipurpose blade in work bowl. Add sausage mixture, bread crumbs, Worcestershire sauce, mustard, pepper sauce, and cheese. Process until mixed, 3 to 5 seconds.

Arrange mushrooms cap side down in 13 x 9 x 2-inch baking pan. Spoon and press sausage mixture into openings, mounding stuffing. Bake at 350°F for 15 to 20 minutes, or until mushrooms are tender. Sprinkle with chives, if desired.

Yield: 5 servings (3 mushrooms per serving).

Tip: Filling may be made up to one day in advance; refrigerate. Warm to room temperature before stuffing mushrooms.

Per Serving: About 230 cal, 11 g pro, 10 g carb, 17 g total fat, 8 g sat fat, 45 mg chol, 390 mg sod.

# Cheddar Wheat Crackers

---

- 2 ounces sharp Cheddar cheese, chilled
- 1 ounce Parmesan cheese, room temperature
- $\frac{3}{4}$  cup rolled oats
- $\frac{1}{2}$  cup (about 4 oz.) walnut pieces
- 1 cup all-purpose flour
- $\frac{2}{3}$  cup whole wheat flour
- 2 teaspoons sugar
- $\frac{3}{4}$  teaspoon salt
- $\frac{1}{2}$  teaspoon baking soda
- 2 tablespoons shortening
- 1 tablespoon butter or margarine, slightly softened
- $\frac{1}{2}$  cup buttermilk
- 1 egg, beaten
- 1 tablespoon water
- 1 teaspoon coarse salt, divided
- 2 tablespoons black sesame seeds\*, divided
- 2 tablespoons white sesame seeds\*, divided

Position 4 mm shredding disc in work bowl. Add Cheddar and Parmesan cheeses. Process to shred. Remove and set aside.

Exchange shredding disc for multipurpose blade in work bowl. Add oats and nuts. Pulse 3 to 4 times, about 5 seconds each time, or until finely ground. Add all-purpose and whole wheat flours, sugar, salt, and baking soda. Process until mixed, 5 to 10 seconds. Add shortening and butter. Pulse 4 to 5 times, about 2 seconds each time, or until crumbly. Add cheeses. Pulse 2 to 3 times, about 2 seconds each time, or until mixed. With processor running, add buttermilk through the small feed tube. Process until stiff dough forms, 20 to 25 seconds, scraping sides of bowl if necessary.

In small bowl, combine egg and water. Set aside.

Remove dough to lightly floured work surface. Form into a ball; divide into 2 portions. Cover 1 portion; roll 1 portion into a 10 x 10-inch square. Place in center of large lightly greased baking sheet. Roll evenly into a 12 x 12-inch square. Brush with egg mixture. Sprinkle with  $\frac{1}{2}$  teaspoon coarse salt, 1 tablespoon black sesame seeds, and 1 tablespoon white sesame seeds. Roll lightly with rolling pin. With pastry wheel, pizza cutter, or sharp knife, score to form 36 squares, or other desired shape. Do not separate. Repeat with remaining dough, egg mixture, salt, and sesame seeds.

Bake at 350°F for about 25 minutes, or until deep golden brown. Outside crackers may start to brown first. Remove them to a cooling rack, and continue baking until center crackers are deep golden brown. Remove to cooling rack.

Yield: 6 dozen (about 6 crackers per serving).

\*Other cracker toppings might include garlic powder, onion powder, sliced almonds, poppy seeds, or sunflower seeds.

Per Serving: About 200 cal, 7 g pro, 20 g carb, 11 g total fat, 3 g sat fat, 30 mg chol, 470 mg sod.

# Caramelized Onion Puff Pastry Squares

---

- 6 ounces Gouda or smoked Gouda cheese, wax removed
- 1 jumbo yellow onion, cut into quarters lengthwise
- 1 tablespoon vegetable oil
- 1 tablespoon brown sugar
- 1 tablespoon balsamic vinegar
- $\frac{1}{4}$  teaspoon coarsely ground black pepper
- $\frac{1}{8}$  teaspoon salt
- 1 sheet (from 17 $\frac{1}{4}$ -oz. pkg.) frozen puff pastry, thawed
- 2 tablespoons chopped fresh parsley leaves, if desired

Position 4 mm shredding disc in work bowl. Add Gouda cheese. Process to shred. Remove and set aside.

Exchange shredding disc for 2 mm slicing disc in work bowl. Add onion. Process to slice.

In large skillet or Dutch oven over medium-high heat, heat oil until it sizzles. Add onions. Cook 5 to 10 minutes, or until onions are limp, stirring occasionally. Stir in brown sugar and vinegar. Cover. Cook, stirring occasionally, over medium-low heat about 35 minutes, or until soft and light golden. Uncover; continue cooking until liquid evaporates. Stir in pepper and salt. Set aside.

On lightly floured surface, roll puff pastry into a 12-inch square. Pierce with a fork. With pizza cutter or sharp knife, cut pastry into 36 pieces. Place on ungreased baking sheet.

Bake at 400°F for 10 to 12 minutes, or until pastry puffs and edges begin to brown. Remove from oven. With back of spoon, make indentation in each square. Spoon onion mixture into each square and sprinkle with cheese. Bake at 400°F for 3 to 5 minutes, or until pastry is golden brown and cheese melts. Garnish with parsley, if desired.

Yield: 12 servings (3 squares per serving).

Per Serving: About 190 cal, 5 g pro, 13 g carb, 13 g total fat, 4 g sat fat, 15 mg chol, 190 mg sod.

## Hot Artichoke Dip

---

- 4 ounces Asiago or Parmesan cheese, room temperature
- 2 green onions, cut into 1-inch pieces
- ½ red or green jalapeno pepper, seeded and cut into quarters
- 1 small clove garlic
- 1 can (14 oz.) artichoke hearts, well drained and cut into halves
- ¾ cup mayonnaise
- 1 package (3 oz.) cream cheese, cut into 1-inch pieces

Position 4 mm shredding disc in work bowl. Add Asiago cheese. Process to shred. Remove and set aside.

Exchange shredding disc for multipurpose blade in work bowl. With processor running, add onions, jalapeno pepper, and garlic through the small feed tube. Process until finely chopped, about 5 seconds. Add artichoke hearts. Pulse 1 to 2 times, about 2 seconds each time, or until coarsely chopped. Add mayonnaise, cream cheese, and Asiago cheese. Process until blended, about 5 seconds.

Remove to greased 9-inch quiche pan or pie plate. Bake at 375°F for 15 to 20 minutes, or until hot. Serve with crackers, French bread, tiny corn muffins, or crisp vegetables.

Yield: 24 servings (2 tablespoons per serving).

Per Serving: About 90 cal, 2 g pro, 1 g carb, 8 g total fat, 2.5 g sat fat, 10 mg chol, 130 mg sod.

## Brandied Cheese Spread

---

- 8 ounces smoked Cheddar cheese, chilled
- 8 ounces Gruyere cheese, room temperature
- 1 small shallot
- 1 package (8 oz.) cream cheese, cut into 1-inch pieces
- 4 ounces blue cheese, crumbled
- ½ cup butter or margarine, softened
- 3 tablespoons brandy

Position 4 mm shredding disc in work bowl. Add Cheddar cheese. Process to shred. Add Gruyere cheese. Process to shred. Remove and set aside.

Exchange shredding disc for multipurpose blade in work bowl. With processor running, add shallot through the small feed tube. Process until finely chopped, about 5 seconds. Add shredded cheese and remaining ingredients. Process until smooth and blended, 15 to 20 seconds.

Refrigerate several hours to blend flavors. Bring to room temperature before serving with crostini or crackers, if desired.

Yield: 36 servings (2 tablespoons per serving).

Tip: Spread may be made 2 days in advance and refrigerated.

Per Serving: About 110 cal, 5 g pro, 1 g carb, 10 g total fat, 6 g sat fat, 30 mg chol, 125 mg sod.

## Roasted Salsa Verde

---

- 2 mild yellow chile peppers, cut into halves and seeded*
- 1 serrano chile pepper, cut into halves and seeded*
- 2 cloves garlic, peeled*
- 1 pound fresh tomatillos, husks removed*
- ½ red bell pepper, seeded and cut into 1½-inch pieces*
- 1 small onion, cut into quarters*
- 1 tablespoon olive or vegetable oil*
- 1 tablespoon fresh lime juice*
- 1 teaspoon sugar*
- ½ teaspoon salt*

Place yellow and serrano peppers, garlic, tomatillos, bell pepper, and onion in 15 x 10 x 2-inch baking pan. Drizzle with oil; toss to coat. On top rack, bake at 450°F for 20 to 25 minutes, or until tomatillos are blistered and garlic is tender, stirring once or twice. Cool slightly.

Position multipurpose blade in work bowl. Add vegetable mixture with any accumulated juices, lime juice, sugar, and salt. Pulse 2 to 3 times, about 1 second each time, or until chopped. Serve chilled or at room temperature with skewered grilled chicken or shrimp, or tortilla chips.

Yield: 24 servings (2 tablespoons per serving).

Tip: May be made 1 to 2 days in advance, if desired.

Per Serving: About 15 cal, 0 g pro, 2 g carb, 1 g total fat, 0 g sat fat, 0 mg chol, 50 mg sod.

## Dilled Sour Cream Cucumbers and Onions

---

- 2 *medium cucumbers*
- 1 *teaspoon salt*
- ½ *small onion*
- ¾ *cup sour cream*
- ¼ *cup mayonnaise*
- ¼ *cup loosely packed fresh dill*
- 1 *tablespoon white wine vinegar*
- 2 *teaspoons sugar*
- ¼-½ *teaspoon black pepper*

Position 2 mm slicing disc in work bowl. Add cucumbers in batches. Process to slice. Remove to medium mixing bowl. Sprinkle with salt; toss to coat. Let stand ½ hour. Drain and spread on paper towels. Set aside.

Position 2 mm slicing disc in work bowl. Add onion. Process to slice. Remove to medium mixing bowl.

Exchange slicing disc for multipurpose blade in work bowl. Add remaining ingredients. Process until well blended, 5 to 10 seconds.

Add sour cream mixture and cucumbers to onions. Toss to coat. Cover and refrigerate at least 1 hour. Serve within 24 hours.

Yield: 6 servings (½ cup per serving).

Per Serving: About 150 cal, 1 g pro, 6 g carb, 13 g total fat, 4.5 g sat fat, 20 mg chol, 450 mg sod.

## White Balsamic Vinaigrette

---

- 1 *tablespoon fresh basil leaves*
- 1 *tablespoon fresh oregano leaves*
- 1 *clove garlic*
- 3 *tablespoons white balsamic vinegar\**
- 3 *tablespoons white wine vinegar\**
- ½ *teaspoon salt*
- ¼ *teaspoon dry mustard*
- ½ *teaspoon ground red pepper*
- ¾ *cup extra virgin olive oil*

Position mini bowl and mini blade in work bowl. With processor running, add basil, oregano, and garlic through the small feed tube. Process until chopped, 5 to 8 seconds. Scrape sides of bowl. With processor running, add balsamic vinegar, wine vinegar, salt, mustard, and red pepper. Process until mixed, about 5 seconds. With processor running, slowly drizzle oil through the small feed tube. Process until smooth and thick. Serve with green salads.

Yield: 8 servings (2 tablespoons per serving).

\*Three tablespoons each of dark balsamic vinegar and red wine vinegar may be substituted.

Per Serving: About 190 cal, 0 g pro, 1 g carb, 21 g total fat, 3 g sat fat, 0 mg chol, 150 mg sod.

## Mediterranean Hot Chicken Salad

---

3 cups (about 1 lb.)  
cooked chicken  
chunks

¼ cup whole pitted  
kalamata olives

3 green onions, cut  
into 1-inch pieces

½ bulb fennel, cut into  
halves lengthwise

½ cup mayonnaise\*

¼ cup sour cream\*

2 teaspoons  
all-purpose flour

1 tablespoon fresh  
oregano leaves

1 tablespoon lemon  
juice

¼ teaspoon salt

⅛ teaspoon black  
pepper

½ cup (2 oz.) crumbled  
feta cheese

¼ cup pine nuts

Position multipurpose blade in work bowl. Add chicken, olives, and onions. Pulse 4 to 6 times, 1 to 2 seconds each time, or until coarsely chopped. Remove to large mixing bowl.

Exchange multipurpose blade for 2 mm slicing disc. Add fennel. Process to slice. Add to mixing bowl.

Exchange slicing disc for mini bowl and mini blade in work bowl. Add all remaining ingredients except cheese and nuts. Process until mixed, 10 to 12 seconds. Add to mixing bowl. Add cheese to mixing bowl; stir to combine.

Spread into greased 8 x 8 x 2-inch baking pan. Sprinkle with pine nuts. Bake at 375°F for 20 to 25 minutes, or until thoroughly heated. Serve with pitas, flatbread, or lettuce wraps.

Yield: 5 servings (about ¾ cup per serving).

\*Light mayonnaise and light sour cream may be substituted.

Per Serving: About 420 cal, 26 g pro, 6 g carb, 33 g total fat, 7 g sat fat, 65 mg chol, 550 mg sod.

## Creamy Citrus Dressing

---

¾ cup mayonnaise

½ cup marshmallow  
crème

1 package (3 oz.)  
cream cheese, cut  
into 1-inch pieces

1 tablespoon fresh  
lime juice

1 medium seedless  
orange, peeled and  
sectioned

¼-½ teaspoon grated lime  
peel, if desired

Position multipurpose blade in work bowl. Add mayonnaise, marshmallow crème, and cream cheese. Process until creamy, about 1 minute. Scrape sides of bowl. Add lime juice, orange, and lime peel, if desired. Process until orange is finely chopped, 20 to 25 seconds. Serve with fruit salads.

Yield: 12 servings (2 tablespoons per serving).

Per Serving: About 140 cal, 1 g pro, 4 g carb, 13 g total fat, 3 g sat fat, 10 mg chol, 100 mg sod.

# Chicken Wild Rice Salad

---

- 2 *green onions, cut into 1-inch pieces*
- 1 *pound boneless, skinless chicken breast halves, grilled or broiled and cooled*
- ½ *large red bell pepper, seeded and cut into quarters lengthwise*
- 1 *medium rib celery*
- 2 *cups cooked wild rice, cooled*

## Dressing

- ½ *cup vegetable oil*
- ¼ *cup white wine or rice vinegar*
- 2 *tablespoons Dijon mustard*
- ½ *teaspoon salt*
- ½ *teaspoon coarsely ground black pepper*
- ½ *teaspoon hot pepper sauce*

Position multipurpose blade in work bowl. Add onions. Pulse 1 to 2 times, about 2 seconds each time, or until chopped.

Exchange multipurpose blade for 2 mm slicing disc in work bowl. Add chicken, bell pepper, and celery in batches. Process to slice. Remove to large mixing bowl. Add rice; toss to mix.

Exchange slicing disc for multipurpose blade in work bowl. Add dressing ingredients. Process until smooth, 3 to 5 seconds. Pour dressing over salad mixture. Toss to coat. Refrigerate at least 1 hour before serving.

Yield: 5 servings.

Tip: Entire salad may be assembled 1 day in advance and refrigerated.

Per Serving: About 370 cal, 22 g pro, 16 g carb, 25 g total fat, 4.5 g sat fat, 50 mg chol, 450 mg sod.

# Asian Coleslaw

---

- 1 *package (3 oz.) ramen noodles (shrimp, chicken, or vegetable flavor)*
- ½ *large head (about 1 lb.) Napa cabbage, cored*
- ½ *medium red onion*
- ½ *cup salted sunflower seeds*

## Dressing

- ¼ *cup vegetable oil*
- 2 *tablespoons rice vinegar or rice wine*
- 2 *tablespoons sugar*

Remove and reserve seasoning packet from noodles. Crumble noodles and place on baking sheet. Bake at 375°F for 5 minutes, or until toasted. Cool.

Position 2 mm slicing disc in work bowl. Add cabbage and onion in batches, cutting to fit feed tube if necessary. Process to slice. Remove to large mixing bowl. Add sunflower seeds and noodles; toss to mix.

Exchange slicing disc for multipurpose blade in work bowl. Add oil, vinegar, sugar, and contents of seasoning packet. Process until blended and sugar is dissolved, 10 to 15 seconds. Pour dressing over salad. Toss to coat.

Chill at least 1 hour before serving to blend flavors.

Yield: 12 servings (½ cup per serving).

Per Serving: About 110 cal, 2 g pro, 9 g carb, 8 g total fat, 1.5 g sat fat, 0 mg chol, 115 mg sod.



# Broccoli Kohlrabi Salad

---

- 1 stalk (about  $\frac{3}{4}$  lb.) broccoli
- 2 bulbs kohlrabi, peeled and cut into eighths lengthwise
- 1 large carrot, peeled

## Dressing

- $\frac{1}{2}$  cup vegetable oil
- 3 tablespoons red wine vinegar
- 1 tablespoon fresh lemon juice
- 2 green onions, cut into 1-inch pieces
- 1 teaspoon prepared mustard
- 1 teaspoon sugar
- $\frac{1}{2}$  teaspoon coarsely ground black pepper
- $\frac{1}{4}$  teaspoon salt

Position 2 mm slicing disc in work bowl. Add broccoli (stalk and florets), cutting to fit feed tube if necessary. Process to slice. Add kohlrabi. Process to slice.

Exchange slicing disc for 4 mm shredding disc in work bowl. Add carrot. Process to shred. Remove vegetable mixture to large mixing bowl.

Exchange shredding disc for multipurpose blade in work bowl. Add dressing ingredients. Process until smooth, 10 to 15 seconds. Pour dressing over vegetables. Toss to coat.

Chill at least 1 hour to blend flavors.

Yield: 10 servings ( $\frac{1}{2}$  cup per serving).

Per Serving: About 90 cal, 2 g pro, 5 g carb, 8 g total fat, 1.5 g sat fat, 0 mg chol, 85 mg sod.

## Cheddar Broccoli Soup

- 8 ounces sharp Cheddar cheese, chilled
- 1 small onion, cut into halves lengthwise
- 1 rib celery, cut into 2½-inch pieces
- 2 tablespoons butter or margarine
- 1 large head (about 1 lb.) broccoli
- 3 cups chicken broth
- 2 cups milk, divided
- ¼ cup all-purpose flour
- 2 teaspoons Dijon mustard
- 1 teaspoon curry powder, if desired
- ⅛ teaspoon hot pepper sauce

Position 4 mm shredding disc in work bowl. Add cheese. Process to shred. Remove and set aside.

Exchange shredding disc for 2 mm slicing disc in work bowl. Add onion and celery. Process to slice. Melt butter in large saucepan or Dutch oven over medium heat. Remove onion and celery to saucepan. Cook 2 to 3 minutes, or until crisp-tender, stirring occasionally.

Cut stems from broccoli, and peel tough coating from stems. Cut florets into small pieces. Position 2 mm slicing disc in work bowl. Add broccoli stems. Process to slice. Remove to saucepan.

Add broccoli florets and broth to saucepan. Bring to a boil over medium-high heat. Reduce heat; partially cover and simmer 6 to 10 minutes, or until broccoli is crisp-tender, stirring occasionally. Remove from heat.

Exchange slicing disc for multipurpose blade in work bowl. With slotted spoon, remove vegetables from saucepan to work bowl. Add ¾ cup milk. Process until chopped, 5 to 8 seconds. Set aside.

In medium mixing bowl, whisk flour into remaining 1¼ cups milk, whisking until smooth. Add mustard, curry powder, if desired, and pepper sauce. Stir until combined.

Add milk mixture to broth in saucepan. Cook and stir over medium-high heat until bubbly and slightly thickened. Reduce heat to low. Add all but ¼ cup shredded cheese; stir until melted.

Add broccoli mixture to saucepan. Heat thoroughly. Garnish with remaining ¼ cup cheese.

Yield: 7 servings (1 cup per serving).

Per Serving: About 250 cal, 13 g pro, 14 g carb, 16 g total fat, 9 g sat fat, 50 mg chol, 740 mg sod.

# Roasted Butternut Squash Soup with Herb Pistou

---

## Soup

- 1 *large (about 2½ lb.) butternut squash, peeled, seeded, and cut into quarters lengthwise*
- 1 *large onion, cut into halves lengthwise*
- 2 *large cloves garlic, cut into quarters*
- 2 *tablespoons olive oil*
- 5 *cups chicken broth, divided*
- 1 *can (15 oz.) pumpkin puree, divided*
- <sup>3</sup>/<sub>4</sub> *teaspoon salt*
- <sup>1</sup>/<sub>4</sub> *teaspoon cayenne pepper*
- 1 *cup whipping cream*

Position 2 mm slicing disc in work bowl. Add squash in batches. Process to slice. Remove to large mixing bowl. Add onion. Process to slice. Add onion and garlic to squash. Drizzle with oil; toss to coat. Spread in 15 x 10 x 1-inch pan. Bake at 450°F for 30 to 35 minutes, or until tender, stirring once or twice. (Pan will be very full at first but decreases as vegetables cook.) Cool slightly.

Exchange slicing disc for multipurpose blade in work bowl. Add half of roasted vegetable mixture and juices, <sup>3</sup>/<sub>4</sub> cup broth, half of pumpkin, salt, and cayenne pepper. Process until smooth, about 30 seconds. Remove to Dutch oven. Repeat with remaining half of roasted vegetable mixture, <sup>3</sup>/<sub>4</sub> cup broth, and remaining half of pumpkin. Remove to Dutch oven. Stir in remaining 3½ cups broth.

Cook and stir over medium heat until thoroughly heated. Stir in cream; heat just until hot. Top each serving with about 2 teaspoons Herb Pistou.

## Pistou Sauce

- 2 *cups loosely packed fresh parsley leaves*
- <sup>1</sup>/<sub>4</sub> *cup loosely packed fresh sage leaves*
- 2 *tablespoons fresh thyme leaves*
- 1 *clove garlic*
- 1 *teaspoon lemon juice*
- <sup>1</sup>/<sub>4</sub> *teaspoon salt*
- <sup>1</sup>/<sub>8</sub> *cup olive oil*

Position mini bowl and mini blade in work bowl. Add parsley, sage, thyme, and garlic. Process until finely chopped, 20 to 25 seconds. Add lemon juice and salt. With processor running, gradually add oil through the small feed tube. Process until well mixed, 20 to 25 seconds.

Yield: 10 servings (1 cup per serving).

Per Serving: About 220 cal, 3 g pro, 19 g carb, 16 g total fat, 6 g sat fat, 30 mg chol, 690 mg sod.

# Pan-Fried Veggie Burgers

---

- 8 ounces Monterey Jack cheese, chilled
- 3 firm Roma tomatoes, cored
- 2 large cloves garlic
- ¼ small red onion, cut into 1-inch pieces
- ¼ medium green bell pepper, cut into 1-inch pieces
- 1 can (15 oz.) pinto or kidney beans, well drained
- 1 can (8½ oz.) whole kernel corn, drained
- 2 cups cooked brown rice (not instant)
- ½ cup dry bread crumbs
- 1 teaspoon ground cumin
- ¾ teaspoon dried oregano
- ¾ teaspoon black pepper
- ¼ teaspoon cayenne pepper
- ¼ teaspoon salt
- 1-2 tablespoons olive oil
- 1-2 tablespoons butter or margarine

Position 2 mm slicing disc in work bowl. Add cheese. Process to slice. Remove and set aside. Add tomatoes. Process to slice. Remove and set aside.

Exchange slicing disc for multipurpose blade in work bowl. With processor running, add garlic through the small feed tube. Process until finely chopped, 5 to 8 seconds. Add onion and bell pepper. Pulse 3 to 5 times, about 2 seconds each time, or until chopped. Add beans, corn, rice, bread crumbs, cumin, oregano, black pepper, cayenne pepper, and salt. Pulse 3 to 4 times, about 1 second each time, or until just mixed. Shape into 8 patties (about ⅓ cup each).

In large nonstick skillet over medium heat, heat olive oil and butter. Add patties in batches, if necessary. Cook about 4 minutes, or until golden brown. Carefully turn. Top each patty with cheese. Reduce heat to medium-low. Cook 5 to 6 minutes, or until patties are golden brown and cheese is melted.

If desired, serve with whole wheat sandwich buns or pita pockets, tomato slices, leaf lettuce, mayonnaise, and mustard.

Yield: 8 servings.

Per serving: About 290 cal, 12 g pro, 31 g carb, 13 g total fat, 6 g sat fat, 35 mg chol, 340 mg sod.

# Muffaletta Sandwiches

---

- 1 *medium plum tomato*
- 2 *large fresh basil leaves*
- 2 *tablespoons fresh parsley leaves*
- 2 *large cloves garlic*
- $\frac{1}{8}$  *small red onion, peeled and cut into 1-inch pieces*
- $\frac{1}{4}$  *cup pimiento-stuffed green olives*
- $\frac{1}{2}$  *cup pitted ripe olives*
- $\frac{1}{2}$  *cup pitted kalamata olives*
- $\frac{1}{4}$  *cup prepared roasted red peppers, drained*
- 1 *tablespoon white wine vinegar*
- $\frac{1}{4}$  *teaspoon dried oregano*
- $\frac{1}{4}$  *teaspoon coarsely ground black pepper*
- $\frac{1}{4}$  *cup extra virgin olive oil*
- 2 *loaves French bread\*, cut into thirds and split lengthwise*
- $\frac{1}{2}$  *pound thinly sliced salami*
- $\frac{1}{2}$  *pound thinly sliced smoked ham or prosciutto*
- 6 *slices provolone cheese*

Position 2 mm slicing disc in work bowl. Add tomato. Process to slice. Remove and set aside.

Exchange slicing disc for mini bowl and mini blade in work bowl. With processor running, add basil and parsley through the small feed tube. Process until chopped, about 5 seconds. With processor running, add garlic. Process until chopped, 5 to 10 seconds. Add onion. Process until chopped, about 3 seconds, scraping sides of bowl if necessary. Add green, ripe, and kalamata olives, roasted red peppers, vinegar, oregano, black pepper, and oil. Process until blended, 15 to 20 seconds.

Spread about 2 tablespoons olive mixture on each side of bread. Top with reserved tomatoes, salami, ham, and cheese. To warm, if desired, wrap each sandwich loosely in foil. Bake at 375°F for 15 to 20 minutes, or until hot and cheese is melted.

Yield: 6 servings.

\*Six hoagie buns may be substituted for bread.

Tip: Olive mixture may be made 1 to 2 days in advance and refrigerated. Also, serve it as a dip with crackers or toasted pita triangles.

Per Serving: About 720 cal, 33 g pro, 51 g carb, 41 g total fat, 14 g sat fat, 70 mg chol, 2410 mg sod.

## French Onion Soup

---

- 8 ounces Gruyere or Swiss cheese, room temperature
- 2 jumbo yellow onions, cut into halves lengthwise
- 3 tablespoons butter or margarine
- 1 tablespoon all-purpose flour
- ½ teaspoon black pepper
- 3 cups beef broth
- 1½ cups chicken broth
- ½ cup dry sherry
- 1 teaspoon Worcestershire sauce
- 6 diagonal slices (½-in. thick) French bread, lightly toasted
- 3 ounces freshly grated Parmesan cheese

Position 4 mm shredding disc in work bowl. Add Gruyere cheese. Process to shred. Remove and set aside.

Exchange shredding disc for 2 mm slicing disc in work bowl. Add onions in batches. Process to slice.

In Dutch oven over medium-high heat, melt butter. Add onions. Cook and stir 5 to 10 minutes, or until onions are tender. Add flour and pepper; mix well. Add beef and chicken broths, sherry, and Worcestershire sauce. Heat to boiling. Reduce heat; simmer 10 to 15 minutes, or until flavors are blended.

Spoon about 1 cup soup into each of 6 individual oven-proof bowls. Top with bread and Gruyere cheese. Sprinkle with Parmesan cheese. Place under broiler, 4 to 6 inches from heat, for 2 to 3 minutes, or until cheese is melted and bubbly.

Yield: 6 servings (1 cup per serving).

Per Serving: About 400 cal, 21 g pro, 25 g carb, 23 g total fat, 13 g sat fat, 65 mg chol, 1170 mg sod.

## Chipotle-Mustard Ham Spread

---

- ¼ small onion
- 1 small chipotle chile in adobo sauce (from 7 or 11-oz. can)
- ½-1 teaspoon adobo sauce
- ¼ cup mayonnaise
- 2 tablespoons prepared honey mustard salad dressing
- ½ rib celery, cut into 1-inch pieces
- 2 cups cubed cooked ham

Position multipurpose blade in work bowl. With processor running, add onion and chile through the small feed tube. Process until chopped, about 5 seconds. Scrape sides of bowl. Add adobo sauce, mayonnaise, salad dressing, and celery. Process until mixed, about 10 seconds, scraping sides of bowl if necessary. Add ham. Pulse 6 to 7 times, about 1 second each time, scraping sides of bowl if necessary. Spread on crackers or bread, if desired.

Yield: 4 servings (½ cup per serving).

Per Serving: About 350 cal, 18 g pro, 2 g carb, 29 g total fat, 7 g sat fat, 70 mg chol, 270 mg sod.

## Layered Eggplant and Roasted Red Pepper Casserole

- 1 medium (about 1½ lb.) eggplant
- 3 tablespoons olive oil
- 4 ounces mozzarella cheese, chilled
- 2 ounces Parmesan cheese, cut into ¾-inch pieces and room temperature
- 1 cup ricotta cheese
- 1 egg
- ¼ teaspoon salt
- ¼ teaspoon black pepper
- 2 cups prepared tomato basil pasta sauce, divided
- 1 jar (7 oz.) roasted red peppers, well drained

Position 2 mm slicing disc in work bowl. Cut eggplant into 2½-inch lengths to fit feed tube. Process to slice. Remove to greased 15 x 10 x 1-inch pan, and arrange evenly. Drizzle with oil. Bake at 450°F for 5 to 8 minutes, or until slightly tender.

Meanwhile, exchange slicing disc for 4 mm shredding disc. Add mozzarella cheese. Process to shred. Remove and set aside.

Exchange shredding disc for multipurpose blade in work bowl. With processor running, add Parmesan cheese through the small feed tube. Process until grated, 25 to 30 seconds. Add ricotta cheese, egg, salt, and black pepper. Process until mixed, 10 to 15 seconds.

Pour 1 cup pasta sauce into greased 12 x 8 x 2-inch baking pan. Layer half of eggplant on top of sauce. Top with half of red peppers and half of ricotta cheese mixture. Repeat layers of eggplant, red peppers, and ricotta cheese mixture. Top with remaining 1 cup pasta sauce and mozzarella cheese. Bake at 350°F for 30 to 40 minutes, or until eggplant is tender and casserole is bubbly. Let stand 5 to 10 minutes before serving.

Yield: 8 servings.

Per Serving: About 250 cal, 12 g pro, 19 g carb, 14 g total fat, 6 g sat fat, 50 mg chol, 610 mg sod.

## Spring Mix Basmati Rice

---

- 1 clove garlic
- 1 medium shallot, cut into quarters
- 1 tablespoon olive oil
- ¼ pound (about 1 cup) fresh green beans, trimmed
- 1 small carrot, peeled and cut into halves crosswise
- 1½ cups chicken broth
- 1 cup water
- 1 teaspoon salt
- ¼ teaspoon black pepper
- 1 teaspoon ground coriander, if desired
- 1½ cups basmati or jasmine rice
- ½ pound fresh asparagus
- 2 teaspoons fresh thyme leaves
- 2 tablespoons loosely packed fresh parsley leaves
- ¼ small red bell pepper, cut into quarters

Position multipurpose blade in work bowl. With processor running, add garlic through the small feed tube. Process 5 seconds. Add shallot. Pulse 2 to 3 times, about 2 seconds each time, or until chopped. In large saucepan over medium heat, heat oil. Add shallot mixture. Cook until tender, 1 to 2 minutes, stirring often. Remove from heat; set aside.

Exchange multipurpose blade for 2 mm slicing disc in work bowl. Add green beans and carrot. Process to slice. Remove to saucepan with shallot mixture. Add broth, water, salt, black pepper, and coriander, if desired. Bring to a boil. Stir in rice. Return to boil; reduce heat. Cover, simmer about 15 minutes, or until liquid is absorbed.

Meanwhile, cut tips from asparagus and reserve stalks; set aside. Exchange slicing disc for multipurpose blade in work bowl. With processor running, add thyme and parsley through the small feed tube. Process until chopped, about 3 seconds. Add bell pepper. Pulse 2 to 3 times, 1 to 2 seconds each time, or until coarsely chopped. Exchange multipurpose blade for 2 mm slicing disc in work bowl. Add asparagus stalks. Process to slice. Remove to saucepan with rice mixture. Add asparagus tips; stir well.

Cover; let stand 10 minutes. Fluff with a fork.

Yield: 6 servings (1 cup per serving).

Per Serving: About 200 cal, 4 g pro, 45 g carb, 2.5 g total fat, 0 g sat fat, 0 mg chol, 630 mg sod.

## Honey-Orange Carrots

---

- 1 pound carrots, peeled
- ½ small onion
- ½ cup orange juice
- 2 tablespoons honey
- ¼ teaspoon salt
- ¼ teaspoon black pepper
- 1 tablespoon butter or margarine

Position 2 mm slicing disc in work bowl. Add carrots and onion in batches. Process to slice. Set aside.

In medium skillet, combine orange juice, honey, salt, and pepper. Bring to a boil over medium-high heat. Add carrot mixture; stir to coat. Bring to a boil. Cover; cook over medium heat 5 minutes. Uncover; simmer 10 minutes, or until liquid evaporates and carrots are coated and tender. Add butter; stir to coat.

Yield: 4 servings (½ cup per serving).

Per Serving: About 110 cal, 1 g pro, 22 g carb, 3 g total fat, 2 g sat fat, 10 mg chol, 210 mg sod.



# Loaded Baked Potato Casserole

---

- 3 strips bacon
- 4 ounces extra sharp Cheddar cheese, chilled
- 4 ounces smoked sharp Cheddar cheese, chilled
- 1 ounce Parmesan cheese, room temperature
- 2½ quarts water
- 2 teaspoons salt, divided
- 2 pounds russet potatoes
- ¼ cup loosely packed fresh parsley leaves
- 6 green onions, cut into 1-inch pieces
- 1 container (16 oz.) sour cream
- 2 tablespoons all-purpose flour
- ½ teaspoon coarsely ground black pepper
- 1 slice (3-in. long) French bread
- 1 tablespoon butter or margarine, softened

In 12-inch skillet over medium heat, cook bacon until crisp. Remove bacon, reserving 2 tablespoons drippings; drain bacon on paper towels, crumble, and set aside.

Position 4 mm shredding disc in work bowl. Add Cheddar cheeses and Parmesan cheese in batches, cutting to fit feed tube if necessary. Process to shred. Remove and set aside.

In Dutch oven over high heat, add water and 1½ teaspoons salt; bring to boil. Meanwhile, position 4 mm shredding disc in work bowl. Add potatoes in batches, cutting to fit feed tube if necessary. Process to shred. If desired, rinse potatoes and drain well. When water boils, add potatoes; return to a boil. Cook 1 minute, or until crisp-tender. Drain well.

Exchange shredding disc for multipurpose blade in work bowl. With processor running, add parsley and onions through the small feed tube. Process until chopped, 2 to 3 seconds. Remove and set aside.

In large mixing bowl, combine sour cream, flour, pepper, remaining ½ teaspoon salt, and reserved bacon drippings; mix well. Add potatoes, shredded cheeses, onion mixture, and reserved bacon; toss gently to mix well. Spread into greased 2½-quart baking dish.

Split French bread lengthwise. Butter cut sides; place cut sides together. Cut into 1-inch pieces. Position multipurpose blade in work bowl. Add buttered bread. Process until fine crumbs form, 10 to 12 seconds. Sprinkle crumb mixture over potatoes. Bake at 350°F for 45 to 60 minutes, or until golden brown and edges are bubbly.

Yield: 12 servings (about ¾ cup per serving).

Per Serving: About 290 cal, 9 g pro, 20 g carb, 19 g total fat, 12 g sat fat, 45 mg chol, 520 mg sod.

# Sweet & Sour Cabbage Sauté

---

- ½ head (about 1 lb.) cabbage, cut into wedges*
- 1 tart apple, peeled, cut into quarters, and cored*
- 1 small onion, cut into quarters lengthwise*
- 5 strips bacon*
- 2 tablespoons cider vinegar*
- 2 tablespoons sugar*
- 2 tablespoons water*
- ¼ teaspoon salt*
- ¼ teaspoon black pepper*

Position 2 mm slicing disc in work bowl. Add cabbage, apple, and onion in batches. Process to slice. Set aside.

In large skillet over medium heat, cook bacon until crisp. Remove bacon, drain, and set aside. Add cabbage mixture to bacon drippings. Cook over medium heat until wilted, about 5 minutes, stirring frequently. Add vinegar, sugar, water, salt, and pepper. Cook 5 to 10 minutes, or until tender, stirring occasionally. Crumble bacon over the top.

Yield: 5 servings (½ cup per serving).

Per Serving: About 100 cal, 3 g pro, 16 g carb, 3 g total fat, 1 g sat fat, 5 mg chol, 260 mg sod.

## Szechwan Pork

- 2 large cloves garlic
- 1 piece (2-in. long) peeled gingerroot, cut into quarters
- 2 tablespoons soy sauce
- 1 tablespoon sherry
- 1 teaspoon dark sesame oil
- 1½ teaspoons crushed red pepper flakes
- ¾ pound pork tenderloin, cut into 3-inch pieces and frozen for 40 to 55 minutes
- 1 red or yellow bell pepper, cut into halves lengthwise and seeded
- 1 large rib celery, cut into 2½-inch pieces
- 1 tablespoon vegetable oil, divided
- 4 green onions, cut diagonally into ½-inch slices
- 1 cup chicken broth
- 1 tablespoon cornstarch
- Hot cooked rice or Chinese noodles, if desired

Position multipurpose blade in work bowl. With processor running, add garlic and gingerroot through the small feed tube. Process until chopped, 8 to 10 seconds. Scrape sides of bowl. Add soy sauce, sherry, sesame oil, and red pepper flakes. Process until mixed, about 5 seconds. Scrape sides of bowl.

Exchange multipurpose blade for 2 mm slicing disc in work bowl. Add pork. Process to slice. Remove to shallow pan or large resealable food storage plastic bag; coat pork with marinade. Refrigerate for 1 to 2 hours.

Meanwhile, wash processor. Position 2 mm slicing disc in work bowl. Add bell pepper and celery. Process to slice. Set aside.

In large skillet over medium-high heat, heat 2 teaspoons vegetable oil. Add pork mixture. Cook 4 to 5 minutes, or until pork is no longer pink, stirring occasionally. Continue to cook and stir until liquid evaporates. Remove from skillet.

Add remaining 1 teaspoon vegetable oil to skillet. Add bell pepper, celery, and onions. Cook 3 to 4 minutes, or until crisp-tender, stirring occasionally.

In small bowl, mix broth and cornstarch. Add to vegetables and bring to a boil. Add pork. Cook 1 minute, or until thick and bubbly. Serve over hot cooked rice or Chinese noodles, if desired.

Yield: 4 servings.

Per Serving: About 180 cal, 19 g pro, 6 g carb, 9 g total fat, 2 g sat fat, 50 mg chol, 740 mg sod.

# Beef and Broccoli Stir-Fry

---

- 2 cloves garlic
- 1 egg white
- 1 tablespoon cornstarch, divided
- 2 tablespoons soy sauce, divided
- 1 teaspoon dark sesame oil
- $\frac{1}{4}$  teaspoon crushed red pepper flakes
- $\frac{1}{8}$  teaspoon ginger
- 1 pound beef flank steak, cut into  $2\frac{1}{2}$ -inch wide pieces and frozen for 40-55 minutes
- $\frac{3}{4}$  cup beef broth
- $1\frac{1}{2}$  tablespoons oyster sauce, if desired
- 1 cup fresh mushrooms
- 1 medium onion, cut into halves lengthwise
- $\frac{1}{2}$  medium head (about 8 oz.) broccoli
- 1 medium carrot
- 2 tablespoons vegetable oil, divided
- Hot cooked rice, if desired

Position multipurpose blade in work bowl. With processor running, add garlic through the small feed tube. Process until chopped, 5 to 10 seconds. Add egg white, 1 teaspoon cornstarch, 1 tablespoon soy sauce, sesame oil, red pepper, and ginger. Process until mixed, 5 to 10 seconds. Scrape sides of bowl.

Exchange multipurpose blade for 2 mm slicing disc in work bowl. Add beef. Process to slice. Remove to shallow pan or large resealable food storage plastic bag; coat beef with marinade. Refrigerate for 1 to 2 hours. Wash processor.

Meanwhile, in small bowl combine broth, oyster sauce (if desired), remaining 2 teaspoons cornstarch, and remaining 1 tablespoon soy sauce. Set aside.

Position 2 mm slicing disc in work bowl. Add mushrooms and onion in batches. Process to slice. Cut broccoli florets from stalk; cut florets into small pieces. Set aside. Add stalk and carrot to feed tube. Process to slice. Set aside.

In large skillet or wok over medium-high heat, heat 1 tablespoon vegetable oil. Add beef mixture. Cook and stir for 5 to 8 minutes, or until no longer pink, stirring occasionally. Remove and set aside.

Heat remaining 1 tablespoon oil in skillet or wok over medium-high heat. Add sliced vegetables and broccoli florets; toss to coat. Cover and cook 4 minutes, stirring once. Remove lid; cook and stir about 3 minutes longer, or until crisp-tender. Add broth mixture; bring to a boil. Add beef mixture. Cook and stir until thickened. Serve over hot cooked rice, if desired.

Yield: 5 servings.

Per Serving: About 230 cal, 22 g pro, 9 g carb, 12 g total fat, 3.5 g sat fat, 35 mg chol, 560 mg sod.

# Deep Dish Pizza

## Crust

- 1 cup water
- 2 tablespoons olive oil
- 1 package active dry yeast
- 3 cups all-purpose flour
- 1 ounce freshly grated Parmesan cheese (see TIPS)
- 1 teaspoon sugar
- $\frac{3}{4}$  teaspoon salt
- $\frac{1}{2}$  teaspoon dried basil
- Olive oil
- Cornmeal

## Sauce

- $1\frac{1}{2}$ -2 cups prepared pizza, Alfredo, barbecue, or other favorite sauce

## Topping

- 3 cups cooked sausage or ground beef, sliced pepperoni, Canadian bacon, ham, shrimp, cooked chicken, roasted peppers, fresh mushrooms, olives, onion, roasted garlic, fresh basil leaves, tomato slices, artichoke hearts, capers, or other favorite topping
- 1 pound shredded mozzarella, provolone, Cheddar, Parmesan, or other favorite cheese

In small saucepan, add water and 2 tablespoons oil. Heat over low heat until warm, 105°F to 115°F. Stir in yeast to dissolve. Set aside.

Position dough blade in work bowl. Add flour, Parmesan cheese, sugar, salt, and basil. Process about 5 seconds; scrape sides of bowl. Process until mixed, about 5 seconds, scraping sides of bowl if necessary. With processor running, slowly add yeast mixture. Process  $1\frac{1}{2}$  to 2 minutes; dough will form a ball.

Remove dough to greased bowl, turning dough to grease all sides. Cover; let rise in warm place until double in size, about 45 to 60 minutes.

Grease 14-inch ( $1\frac{1}{2}$  inches deep) pizza pan with olive oil; sprinkle with cornmeal. Punch dough down; pat into large circle. Press into bottom and up sides of pan. Top as desired with sauce, meat and/or vegetables, and cheese.

Bake at 400°F for 5 minutes. Reduce heat to 350°F and bake for 28 to 33 minutes, or until crust is deep golden brown and cheese is bubbly. Let stand 15 minutes before cutting.

Yield: 8 servings.

Per Serving: About 510 cal, 26 g pro, 41 g carb, 26 g total fat, 12 g sat fat, 55 mg chol, 970 mg sod.

## VARIATION

### Thin Crust Pizzas

Prepare dough as directed above and let rise. Grease 2, 12-inch pizza pans with olive oil; sprinkle with cornmeal. Punch dough down; divide into 2 balls. Pat into 12-inch circles, and press onto bottom and sides of pans. Bake at 425°F for 8 minutes.

Top each crust as desired with about 1 cup sauce,  $1\frac{1}{2}$  cups meat and/or vegetables, and 8 ounces cheese. Bake at 425°F for 15 to 20 minutes, or until crust is deep golden brown and cheese is bubbly. If baking both pizzas in one oven, switch racks halfway through baking.

Yield: 8 servings.

Per Serving: About 510 cal, 27 g pro, 42 g carb, 26 g total fat, 12 g sat fat, 55 mg chol, 1020 mg sod.

# Chicken Satay with Peanut Sauce

---

## Chicken

- 2 *cloves garlic*
- 1 *teaspoon coarsely chopped gingerroot*
- $\frac{1}{4}$  *cup soy sauce*
- 2 *tablespoons peanut or vegetable oil*
- 2 *teaspoons brown sugar*
- 1-1 $\frac{1}{4}$  *pounds chicken breast tenders*

Position multipurpose blade in work bowl. With processor running, add garlic and gingerroot through the small feed tube. Process until chopped, 5 to 10 seconds. Add soy sauce, oil, and brown sugar. Process until blended and sugar dissolves, 15 to 20 seconds. Remove to plastic resealable food storage bag or shallow pan.

Add chicken; coat with marinade. Marinate  $\frac{1}{2}$  hour at room temperature or at least 2 hours in refrigerator. Remove chicken from marinade, reserving marinade.

Thread chicken tenders on soaked wooden or oiled metal skewers. Grill over medium-hot coals or broil on oiled broiler pan 4 to 6 inches from heat for 8 to 10 minutes, or until thoroughly cooked, turning once. Brush with any remaining marinade once during cooking, if desired. Serve with warm or room temperature Peanut Sauce.

## Sauce

- $\frac{1}{2}$  *cup coconut milk*
- $\frac{1}{4}$  *cup peanut butter*
- 2 *tablespoons soy sauce*
- $\frac{1}{2}$  *teaspoon red curry paste*

Position multipurpose blade in work bowl. Add all ingredients. Process until blended, 5 to 10 seconds.

Yield: 4 servings.

Per Serving: About 290 cal, 30 g pro, 5 g carb, 17 g total fat, 6 g sat fat, 60 mg chol, 1400 mg sod.

# Herbed Salmon Cakes with Cilantro-Caper Mayonnaise

---

## Mayonnaise

- 3 *tablespoons lightly packed fresh cilantro leaves*
- ½ *cup mayonnaise or salad dressing*
- 1 *tablespoon drained capers*

Position mini bowl and mini blade in work bowl. With processor running, add cilantro through the small feed tube. Process until chopped, 8 to 10 seconds. Scrape sides of bowl. Add mayonnaise and capers. Process until mixed, 10 to 12 seconds. Remove to small bowl; cover and refrigerate.

## Cakes

- 2 *cups French or Italian bread cubes*
- 1 *tablespoon fresh tarragon leaves*
- 1 *strip lemon peel, yellow portion only*
- 2 *green onions, cut into 1-inch pieces*
- ½ *rib celery, cut into 1-inch pieces*
- 1 *egg*
- 2 *teaspoons lemon juice*
- ¼ *teaspoon salt*
- ⅛ *teaspoon black pepper*
- 1 *pound fresh salmon fillets\*, grilled or broiled, and skin removed*
- 1 *tablespoon olive oil*
- 1 *tablespoon butter or margarine*

Position multipurpose blade in work bowl. Add bread. Process until fine crumbs form, about 20 seconds. Remove to shallow pan.

With processor running, add tarragon, lemon peel, and onions through the small feed tube. Process until chopped, 5 to 8 seconds. Scrape sides of bowl. Add celery. Pulse 2 to 3 times, about 2 seconds each time, or until chopped. Add egg, lemon juice, salt, pepper, and ¾ cup bread crumbs. Pulse 2 to 3 times, about 2 seconds each time, or until mixed. Add salmon. Pulse 5 to 6 times, about 2 seconds each time, or just until mixed. Mixture will be soft; chill, if desired, for easier handling.

Shape into 4 cakes, ½-inch thick. Coat both sides of cakes with remaining bread crumbs.

In large skillet over medium heat, heat oil and butter. Add cakes. Cook 5 to 8 minutes, or until golden brown and thoroughly heated, carefully turning once. Serve with Cilantro-Caper Mayonnaise.

Yield: 4 servings.

\*Two 7-ounce cans of salmon, drained, may be substituted, if desired.

Tip: Mayonnaise and uncooked cakes may be made and refrigerated up to 1 day in advance. Cook cakes just before serving.

Per Serving: About 510 cal, 29 g pro, 10 g carb, 38 g total fat, 7 g sat fat, 140 mg chol, 450 mg sod.

## Honey Wheat Bread

- $\frac{2}{3}$  cup milk
- $\frac{1}{3}$  cup water
- 3 tablespoons butter or margarine, cut into pieces
- 3 tablespoons honey
- 1 package active dry yeast
- $1\frac{1}{2}$  cups all-purpose flour
- $1\frac{1}{2}$  cups whole wheat flour
- $\frac{3}{4}$  cup walnut halves or pieces
- $\frac{1}{4}$  cup wheat germ
- 1 teaspoon salt
- 1 teaspoon melted butter or margarine, if desired
- 1 teaspoon wheat germ, if desired

Combine milk, water, 3 tablespoons butter, and honey in small saucepan. Heat over low heat until warm, 105°F to 115°F. Stir in yeast to dissolve. Set aside.

Position dough blade in work bowl. Add all-purpose flour, whole wheat flour, nuts,  $\frac{1}{4}$  cup wheat germ, and salt. Process about 10 seconds; scrape sides of bowl. Process until mixed, about 10 seconds, scraping sides of bowl if necessary. With processor running, slowly add yeast mixture through the small feed tube. Process 1 to  $1\frac{1}{4}$  minutes; dough will form a slightly sticky ball.

Remove dough to greased bowl, turning dough to grease all sides. Cover; let rise in warm place until double in size, about 45 to 60 minutes.

Punch dough down. Shape into a loaf and place in greased  $8\frac{1}{2}$  x  $4\frac{1}{2}$  x  $2\frac{1}{2}$ -inch loaf pan. Cover; let rise in warm place until double in size, 45 to 60 minutes. If desired, brush with melted butter and sprinkle with wheat germ.

Bake at 375°F for 30 to 40 minutes, or until loaf is brown and sounds hollow when tapped. Cool on wire rack.

Yield: 1 loaf (12 servings).

Per Serving: About 200 cal, 6 g pro, 29 g carb, 8 g total fat, 2.5 g sat fat, 10 mg chol, 200 mg sod.



# Country White Bread

---

- ¾ cup water*
- ¼ cup milk*
- 2 tablespoons butter or margarine*
- 1 package active dry yeast*
- 3 cups all-purpose flour*
- 1 tablespoon sugar*
- 1 teaspoon salt*
- 1 teaspoon melted butter or margarine, if desired*

Combine water, milk, and 2 tablespoons butter in small saucepan. Heat over low heat until warm, 105°F to 115°F. Stir in yeast to dissolve. Set aside.

Position dough blade in work bowl. Add flour, sugar, and salt. Process until mixed, about 5 seconds, scraping sides of bowl if necessary. With processor running, slowly add yeast mixture through the small feed tube. Process 1 to 1¼ minutes; dough will form a slightly sticky ball.

Remove dough to greased bowl, turning dough to grease all sides. Cover; let rise in warm place until double in size, 45 to 60 minutes.

Punch dough down. Shape into a loaf and place in greased 8½ x 4½ x 2½-inch loaf pan. Cover; let rise in warm place until double in size, 45 to 60 minutes. Brush with 1 teaspoon melted butter, if desired.

Bake at 375°F for 35 to 40 minutes, or until loaf is deep golden brown and sounds hollow when tapped. Remove loaf from pan immediately. Cool on rack.

Yield: 1 loaf (12 servings).

Per Servings: About 130 cal, 4 g pro, 24 g carb, 2.5 g total fat, 1.5 g sat fat, 5 mg chol, 200 mg sod.

# Country White Bread Variations

---

## **Cinnamon Bread**

After first rising, roll out dough into a 15 x 9-inch rectangle. Spread with 1 tablespoon soft butter or margarine. Sprinkle with 3 tablespoons sugar and 1 teaspoon cinnamon. Starting at short end, roll firmly to form loaf. Pinch to seal ends and bottom seam. Place seam side down in 8½ x 4½ x 2½-inch greased loaf pan. Proceed as directed for white bread.

Yield: 1 loaf (12 servings).

Per Serving: About 150 cal, 4 g pro, 27 g carb, 3.5 g total fat, 2 g sat fat, 10 mg chol, 200 mg sod.

## **Parmesan Pepper Bread**

After first rising, roll out dough into a 15 x 9-inch rectangle. Spread with 1 tablespoon soft butter or margarine. Sprinkle with 3 tablespoons freshly grated Parmesan cheese and ¼ teaspoon coarsely ground black pepper. Starting at short end, roll firmly to form loaf. Pinch to seal ends and bottom seam. Place seam side down in 8½ x 4½ x 2½-inch greased loaf pan. Proceed as directed for white bread.

Yield: 1 loaf (12 servings).

Per Serving: About 150 cal, 4 g pro, 24 g carb, 3.5 g total fat, 2 g sat fat, 10 mg chol, 220 mg sod.

## Cranberry-Walnut Scones

---

- 2 cups all-purpose flour
- 2 teaspoons baking powder
- ¼ teaspoon cinnamon
- ¼ teaspoon nutmeg
- ¼ teaspoon salt
- 2 tablespoons sugar
- ½ cup cold butter or margarine, cut into ½-inch pieces
- 1 egg yolk
- ¾ cup whipping cream
- ¾ cup dried cranberries
- ¾ cup walnut halves or pieces
- 1 teaspoon sugar, if desired

Position multipurpose blade in work bowl. Add flour, baking powder, cinnamon, nutmeg, salt, and 2 tablespoons sugar. Process until thoroughly mixed, about 10 seconds. Add butter. Pulse 5 times, about 2 seconds each time, or until mixture is crumbly.

In small bowl, combine egg yolk and cream. Sprinkle evenly over flour mixture in work bowl. Add cranberries and nuts. Process until dry ingredients are just moistened, about 5 seconds.

Turn onto lightly floured surface. Pat into 7-inch circle, about 1-inch thick. Sprinkle with 1 teaspoon sugar, if desired. Cut into 8 wedges. Place on greased baking sheet. Bake at 400°F for 18 to 20 minutes, or until light golden brown and firm when tapped on top. Serve warm.

Yield: 8 scones (1 scone per serving).

Per Serving: About 350 cal, 5 g pro, 38 g carb, 21 g total fat, 10 g sat fat, 70 mg chol, 200 mg sod.

## Buttermilk Parmesan Biscuits

---

- 2 ounces Parmesan cheese, cut into 1-inch pieces and room temperature
- 2 cups all-purpose flour
- 1 tablespoon baking powder
- 1 teaspoon baking soda
- ¼ teaspoon salt
- ½ cup shortening
- ¾ cup buttermilk
- 2 tablespoons melted butter, if desired

Position multipurpose blade in work bowl. With processor running, add cheese through the small feed tube. Process until grated, 30 to 45 seconds. Add flour, baking powder, baking soda, and salt. Process until mixed, about 3 seconds. Add shortening. Pulse 6 to 8 times, about 1 second each time, or until mixture is crumbly. Pour buttermilk evenly over flour mixture. Pulse 4 to 6 times, about 1 second each time, or until mixture forms a ball. Do not overmix.

Place dough on floured surface. Pat or roll to ½-inch thick. Cut with floured 2-inch round cutter. If desired, gently re-roll dough pieces once to cut additional biscuits. Place on ungreased baking sheet. Brush with melted butter, if desired. Bake at 450°F for 8 to 10 minutes, or until light golden brown.

Yield: 14 biscuits (1 biscuit per serving).

Per Serving: About 130 cal, 4 g pro, 14 g carb, 6 g total fat, 2 g sat fat, 5 mg chol, 320 mg sod.

# Banana Macadamia Nut Bread

---

- 3 *medium ripe bananas*
- 2 *eggs*
- $\frac{1}{2}$  *cup butter or margarine, cut into pieces and softened*
- 3 *tablespoons buttermilk*
- 1 *teaspoon vanilla*
- 1 *cup sugar*
- $1\frac{1}{2}$  *teaspoons baking powder*
- $\frac{1}{2}$  *teaspoon baking soda*
- $\frac{1}{2}$  *teaspoon salt*
- $\frac{1}{4}$  *teaspoon cinnamon*
- 2 *cups all-purpose flour\**
- 1 *jar (3.25 oz.) macadamia nuts*

Position 2 mm slicing disc in work bowl. Add bananas. Process to slice.

Exchange slicing disc for multipurpose blade in work bowl. Add eggs, butter, buttermilk, vanilla, and sugar. Process until creamy, about 45 seconds. Add baking powder, baking soda, salt, and cinnamon. Pulse 3 times, about 1 second each time. Add flour and nuts. Pulse 3 times, about 1 second each time, or until dry ingredients are moistened.

Pour into greased and floured 9 x 5 x 3-inch loaf pan. Bake at 350°F for 55 to 60 minutes, or until toothpick inserted in center comes out clean. Cool in pan 10 minutes. Remove to cooling rack; cool completely.

Yield: 12 servings.

\*If desired, substitute 1 cup whole wheat flour for 1 cup all-purpose flour.

Tip: If using an 8½ x 4½ x 2½-inch loaf pan, bake for 60 to 65 minutes.

Per Serving: About 300 cal, 4 g pro, 40 g carb, 15 g total fat, 5 g sat fat, 55 mg chol, 300 mg sod.

# Velvety Sour Cream Cheesecake

## Crust

- 16 squares (2½ in. each)  
graham crackers,  
broken
- ¼ cup butter or  
margarine, melted

## Filling

- 2 packages (8 oz.  
each) cream cheese,  
softened
- 2 eggs
- 1½ cups sour cream
- ⅔ cup sugar
- 1 teaspoon vanilla
- ⅛ teaspoon salt

Position multipurpose blade in work bowl. Add crackers. Process until fine crumbs form, 40 to 50 seconds. Drizzle butter over crumbs. Process until combined, 15 to 25 seconds. Press in bottom and 1½ inches up sides of 9-inch springform pan. Bake at 350°F for 8 to 10 minutes, or until set. Cool.

Wipe out work bowl. Position multipurpose blade in work bowl. Add cream cheese and eggs. Process until blended, 10 to 15 seconds. Add remaining ingredients. Process until smooth and blended, about 15 seconds, scraping sides of bowl if necessary.

Pour into crust. Bake at 350°F for 40 to 50 minutes, or until edges are set and center is soft-set. Cool 1 to 2 hours on rack. Refrigerate at least 4 hours. Remove sides of pan to slice. If desired, serve with favorite fruit coulis, pie filling, or chocolate or fruit sauce.

Yield: 12 servings.

Per Serving: About 320 cal, 5 g pro, 21 g carb, 24 g total fat, 14 g sat fat, 95 mg chol, 230 mg sod.

# Fresh Fruit Tart

---

## Crust

- 1 *cup all-purpose flour*
- 2 *teaspoons sugar*
- $\frac{1}{4}$  *teaspoon salt*
- $\frac{1}{4}$  *cup cold butter, cut into 1-inch pieces*
- 1 *tablespoon cold shortening*
- 1 *egg yolk*
- 2 *tablespoons ice water*
- 1 *teaspoon lemon juice*
- 1 *egg, blended with 1 tablespoon water*

## Filling

- $\frac{1}{4}$  *cup sugar*
- 1 *tablespoon cornstarch*
- $\frac{1}{8}$  *teaspoon salt*
- $\frac{3}{4}$  *cup half-and-half*
- 2 *egg yolks, beaten*
- $\frac{1}{2}$  *teaspoon vanilla*

## Topping

- 1 *medium peach, peeled, cut into halves, and pit removed*
- 1 *cup fresh strawberries, hulled*
- 2 *tablespoons apple jelly, melted*

Position multipurpose blade in work bowl. Add flour, sugar, and salt. Process until mixed, about 2 seconds. Add butter and shortening. Pulse 3 to 4 times, 2 to 3 seconds each time, or until crumbly. In small bowl, blend 1 egg yolk, 2 tablespoons water, and lemon juice. Sprinkle evenly over flour mixture. Pulse 2 to 4 times, 2 to 3 seconds each time, or until mixture pulls away from sides of bowl and clings together. Remove dough, cover, and chill  $\frac{1}{2}$  hour.

Meanwhile, in small saucepan over medium heat, combine sugar, cornstarch, and salt. Add half-and-half and 2 egg yolks. Cook and stir until very thick. Remove from heat. Add vanilla. Whisk until smooth. Cool completely.

Place dough on floured surface. Roll into a circle 2 inches larger than inverted 10-inch tart pan. Fit into tart pan, being careful not to stretch dough. Trim edges of crust. Prick shell thoroughly with fork. Bake at 425°F for 8 to 12 minutes, or until light golden brown. Brush with egg and water mixture to seal holes. Bake for 1 minute longer to set egg. Cool completely.

Wash processor. Position 2 mm slicing disc in work bowl. Add peach. Process to slice. Remove and set aside. Position 2 mm slicing disc in work bowl. Add strawberries. Process to slice.

Spread custard mixture in crust. Arrange sliced fruit on custard. Carefully brush with melted jelly to cover fruit completely. Refrigerate at least 1 hour before serving.

Yield: 8 servings.

Tip: Tart is best served the same day it is made.

Per Serving: About 230 cal, 4 g pro, 27 g carb, 12 g total fat, 6 g sat fat, 125 mg chol, 130 mg sod.

# Pear Hazelnut Crunch Pie

---

1 9-inch pastry crust  
(see page 54)

## Topping

$1\frac{1}{2}$  cups hazelnuts  
 $\frac{1}{8}$  cup all-purpose flour  
 $\frac{1}{2}$  cup packed brown sugar  
 $\frac{1}{2}$  cup rolled oats  
 $\frac{1}{4}$  teaspoon cinnamon  
 $\frac{1}{4}$  teaspoon nutmeg  
 $\frac{1}{2}$  cup butter or margarine, cut into pieces and softened

## Filling

4 large firm pears, peeled, cut into halves lengthwise, and cored  
 $\frac{1}{4}$  cup granulated sugar  
1 tablespoon all-purpose flour  
1 tablespoon lemon juice  
 $\frac{1}{2}$  teaspoon cinnamon

Fit crust into 9-inch pie plate. Flute edges; set aside.

Position multipurpose blade in work bowl. Add all topping ingredients except butter. Pulse 4 to 5 times, about 2 seconds each time, or until nuts are coarsely chopped. Add butter. Pulse 4 to 5 times, about 3 seconds each time, or until crumbly. Remove and set aside.

Exchange multipurpose blade for 2 mm slicing disc in work bowl. Add pears. Process to slice. Remove to large mixing bowl. Add remaining filling ingredients. Mix well.

Add pear mixture to crust. Cover with hazelnut topping. Loosely cover pie with foil. Bake at 375°F for 45 minutes. Remove foil. Bake an additional 15 to 30 minutes, or until filling is bubbly and fruit is tender.

Yield: 8 servings.

Tip: For apple and pear filling, substitute 2 large crisp apples for 2 pears.

Per Serving: About 560 cal, 7 g pro, 60 g carb, 35 g total fat, 11 g sat fat, 35 mg chol, 80 mg sod.

# Pastry Crust

---

## One Crust

- 1 cup all-purpose flour
- $\frac{1}{4}$  teaspoon salt
- $\frac{1}{4}$  cup cold shortening
- 1 tablespoon cold butter or margarine, cut up
- 2-4 tablespoons ice water

## Two Crusts

- 2 cups all-purpose flour
- $\frac{3}{4}$  teaspoon salt
- $\frac{1}{2}$  cup cold shortening
- 3 tablespoons cold butter or margarine, cut up
- 5-7 tablespoons ice water

Position multipurpose blade in work bowl. Add flour and salt. Process until mixed, about 2 seconds. Add shortening and butter. Pulse 3 to 4 times, 2 to 3 seconds each time, or until crumbly. Sprinkle minimum amount of water evenly over mixture. Pulse 1 to 3 times, 2 to 3 seconds each time, or until mixture pulls away from sides of bowl and dry ingredients are moistened. Add additional water if necessary.

On lightly floured surface, shape into a ball (2 balls for 2-crust pie). Roll each ball into a circle 2 inches larger than inverted pie plate. Fit into pie plate. Proceed as directed in pie recipe.

To bake single crust shell, flute edges of crust. Prick shell thoroughly with fork. Bake at 425°F for 9 to 12 minutes, or until light golden brown. To bake 2-crust pie, follow directions in pie recipe.

Yield: 1 pie (8 servings).

Per Serving (one crust): About 120 cal, 2 g pro, 11 g carb, 8 g total fat, 2.5 g sat fat, 5 mg chol, 75 mg sod.

Per Serving (two crusts): About 260 cal, 4 g pro, 23 g carb, 17 g total fat, 6 g sat fat, 10 mg chol, 220 mg sod.



# Carrot Cake With Cream Cheese Frosting

---

## Cake

- 1 pound (6-7 medium) carrots
- 2 cups sugar
- $\frac{3}{8}$  cup vegetable oil
- 3 eggs
- 2 teaspoons vanilla
- $2\frac{1}{4}$  cups all-purpose flour
- 2 teaspoons baking soda
- 2 teaspoons cinnamon
- $\frac{1}{2}$  teaspoon salt
- $\frac{1}{4}$  teaspoon nutmeg
- $\frac{1}{2}$  cup pecan halves or pieces
- $\frac{1}{4}$  cup raisins
- $\frac{1}{4}$  cup flaked coconut

Position 4 mm shredding disc in work bowl. Add carrots, cutting to fit feed tube if necessary. Process to shred. (Yield should be about 3 cups.)

Exchange shredding disc for multipurpose blade in work bowl. Add sugar, oil, eggs, vanilla, and carrots. Process until thoroughly mixed, 8 to 10 seconds. Scrape sides of bowl. Process 25 to 30 seconds longer to dissolve sugar. Spread flour, baking soda, cinnamon, salt, and nutmeg evenly over carrot mixture in bowl. Pulse 2 times, 2 to 3 seconds each time, or until just blended. Sprinkle nuts, raisins, and coconut evenly over batter. Process until just blended, 2 to 3 seconds.

Pour batter evenly into 2 greased and floured 9-inch round cake pans. Bake at 350°F for about 30 minutes, or until wooden pick inserted in center comes out clean. Cool in pans on rack for 10 minutes. Remove layers from pans; cool completely. Frost with Cream Cheese Frosting.

## Frosting

- $4\frac{1}{2}$  cups powdered sugar
- 6 ounces cream cheese, softened and cut into 8 pieces
- $\frac{1}{4}$  cup butter or margarine, softened
- $\frac{3}{4}$  teaspoon vanilla
- 1-2 teaspoons milk

Position multipurpose blade in work bowl. Add powdered sugar, cream cheese, butter, vanilla, and 1 teaspoon milk. Process until thoroughly mixed, 15 to 20 seconds. With processor running, if necessary, add an additional 1 teaspoon milk through the small feed tube until frosting is spreading consistency.

Yield: 12 servings.

Tip: For rectangular-shaped cake, pour batter into greased and floured 9 x 13 x 2-inch baking pan. Bake at 350°F for 40 to 50 minutes.

Per Serving: About 660 cal, 6 g pro, 103 g carb, 27 g total fat, 9 g sat fat, 80 mg chol, 400 mg sod.

## Vanilla Chocolate Chunk Cookies

---

- ½ cup butter or margarine, softened*
- ½ cup shortening*
- ½ cup granulated sugar*
- ½ cup packed brown sugar*
- 2 eggs\**
- 2 teaspoons vanilla*
- 1 teaspoon baking soda*
- ½ teaspoon salt*
- 2 cups all-purpose flour*
- 1¼ cups white chocolate chunks*
- 1¼ cups milk chocolate chunks*

Position multipurpose blade in work bowl. Add butter, shortening, granulated sugar, and brown sugar. Process until creamy, about 20 seconds. Add eggs, vanilla, baking soda, and salt. Process until well mixed, about 10 seconds. Add flour; evenly sprinkle white and milk chocolate over flour. Pulse 6 to 8 times, 2 to 3 seconds each time, or until mixed.

Drop by level tablespoonfuls on ungreased baking sheets. Bake at 375°F for 8 to 10 minutes, or until light golden brown. Remove to cooling rack.

Yield: 4 dozen (1 cookie per serving).

\*For chewier cookies, use only 1 egg.

Per Serving: About 110 cal, 1 g pro, 13 g carb, 6 g total fat, 3 g sat fat, 15 mg chol, 60 mg sod.

# KitchenAid® Food Processor Warranty for the 50 United States and District of Columbia

This warranty extends to the purchaser and any succeeding owner for Food Processors operated in the 50 United States and District of Columbia.

Length of Warranty:	KitchenAid Will Pay For Your Choice of:	KitchenAid Will Not Pay For:
<p>One Year Full Warranty from date of purchase.</p>	 <p>Hassle-Free Replacement of your Food Processor. See inside front cover for details on how to arrange for service, or call the Customer Satisfaction Center toll-free at <b>1-800-541-6390</b>. OR The replacement parts and repair labor costs to correct defects in materials and workmanship. Service must be provided by an Authorized KitchenAid Service Center. To arrange for service, follow the instructions under the KitchenAid® Food Processor Warranty for Puerto Rico on page 58.</p>	<ul style="list-style-type: none"> <li>A. Repairs when Food Processor is used in other than normal single family home use.</li> <li>B. Damage resulting from accident, alteration, misuse or abuse.</li> <li>C. Any shipping or handling costs to deliver your Food Processor to an Authorized Service Center.</li> <li>D. Replacement parts or repair labor costs for Food Processors operated outside the 50 United States and District of Columbia.</li> </ul>

**KITCHENAID DOES NOT ASSUME ANY RESPONSIBILITY FOR INCIDENTAL OR CONSEQUENTIAL DAMAGES.** Some states do not allow the exclusion or limitation of incidental or consequential damages, so this exclusion may not apply to you. This warranty gives you specific legal rights and you may also have other rights which vary from state to state.

# KitchenAid® Food Processor Warranty for Puerto Rico

---

A limited one year warranty extends to the purchaser and any succeeding owner for Food Processors operated in Puerto Rico. During the warranty period, all service must be handled by an Authorized KitchenAid Service Center. Please bring the Food Processor, or ship it prepaid and

insured, to the nearest Authorized Service Center. Call toll-free **1-800-541-6390**, 8 a.m. to 8 p.m., Monday through Friday, 10 a.m. to 5 p.m., Saturday, Eastern Time to learn the location of a Service Center near you. Your repaired Food Processor will be returned to you prepaid and insured.

## Arranging for Service After the Warranty Expires

---



For service information, call toll-free **1-800-541-6390**, 8 a.m. to 8 p.m., Monday through Friday, 10 a.m. to 5 p.m., Saturday, (Eastern Time) or write to:

Customer Satisfaction Center  
KitchenAid Portable Appliances  
P.O. Box 218  
St. Joseph, MI 49085-0218

## Arranging for Service Outside the 50 United States and Puerto Rico

---

Consult your local KitchenAid dealer or the store where you purchased the

Food Processor for information on how to obtain service.

# Ordering Accessories and Replacement Parts

---

To order accessories or replacement parts for your Food Processor, visit **KitchenAid.com** or call toll-free **1-800-541-6390**, 8 a.m. to 8 p.m., Monday through Friday, 10 a.m. to 5 p.m., Saturday, Eastern Time.

You can also write to:  
Customer Satisfaction Center  
KitchenAid Portable Appliances  
P.O. Box 218  
St. Joseph, MI 49085-0218

## Accessories for Models KFP770 and KFP760:

### Blades and Discs

12-cup Multipurpose Blade	KFP72BL
Dough Blade	KFP72DB
Mini Blade (for Mini Bowl)	KFP7MBL
2 mm (Thin) Slicing Disc	KFP7SL2
2 mm (Thin) Shredding Disc	KFP7SH2
4 mm (Med) Slicing Disc	KFP7SL4
4 mm (Med) Shredding Disc	KFP7SH4
6 mm (Thick) Slicing Disc	KFP7SL6
6 mm (Thick) Shredding Disc	KFP7SH6
Julienne Disc	KFP7JU
French Fry Cutting Disc	KFP7FF
Parmesan/Ice Grating Disc	KFP7PI
5 Disc Set	KFP7DS
<ul style="list-style-type: none"><li>• 6 mm slicing</li><li>• 6 mm shredding</li><li>• French fry</li><li>• Julienne</li><li>• Parmesan/Ice grating</li></ul>	

### Bowls and Covers

Work Bowl Cover with Ultra Wide Mouth™ Feed Tube	KFP7WWC
12-cup Work Bowl	KFP72WB
Mini Bowl with Storage Lid	KFP7MB
Chef's Bowl	KFP72CB

### Specialty Accessories

12-cup Egg Whip	KFP72EW
Citrus Press	KFP7CP
Juice Extractor	KFP7JE

### Other Accessories

2-Piece Food Pusher for Ultra Wide Mouth™ Feed Tube	KFP7WP
Spatula/Cleaning Tool	KFP7SP
Chef's Accessory Case	KFP7SC







FOR THE WAY IT'S MADE.™

® Registered Trademark/™ Trademark of KitchenAid, U.S.A.