

# KRUPS

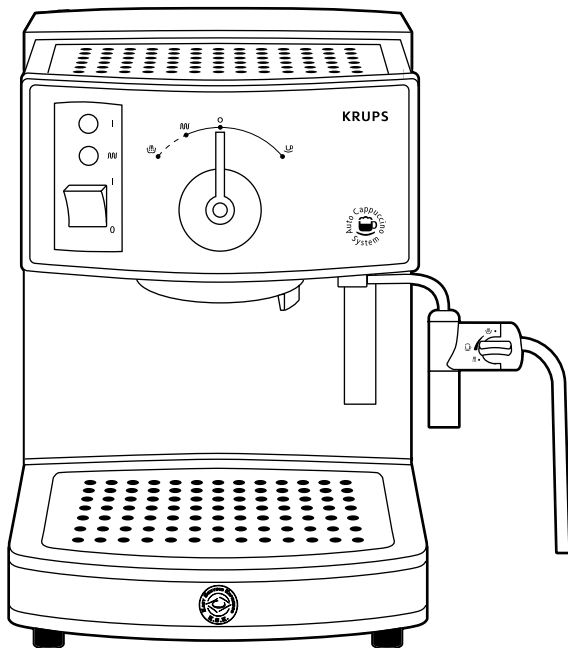

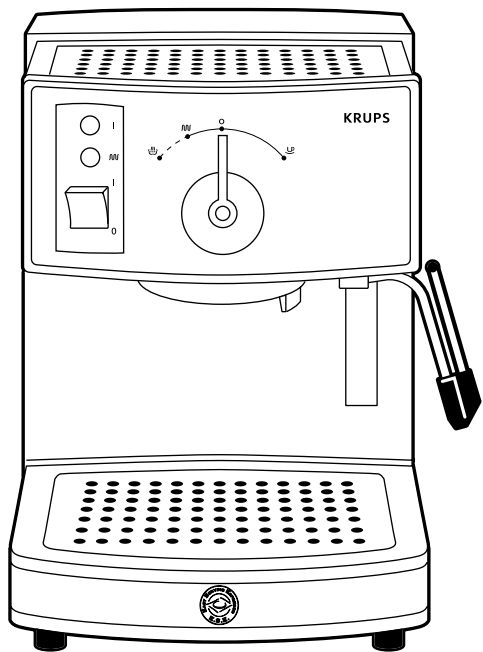

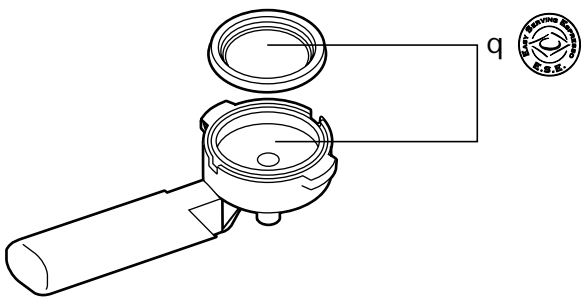

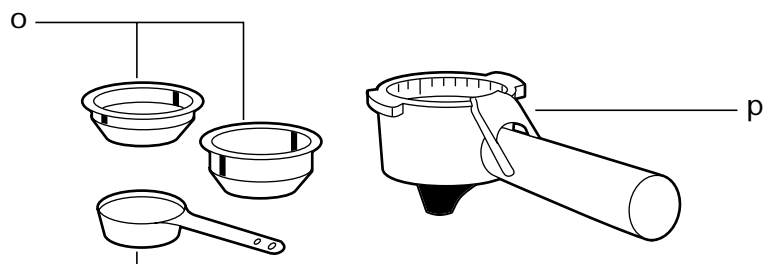
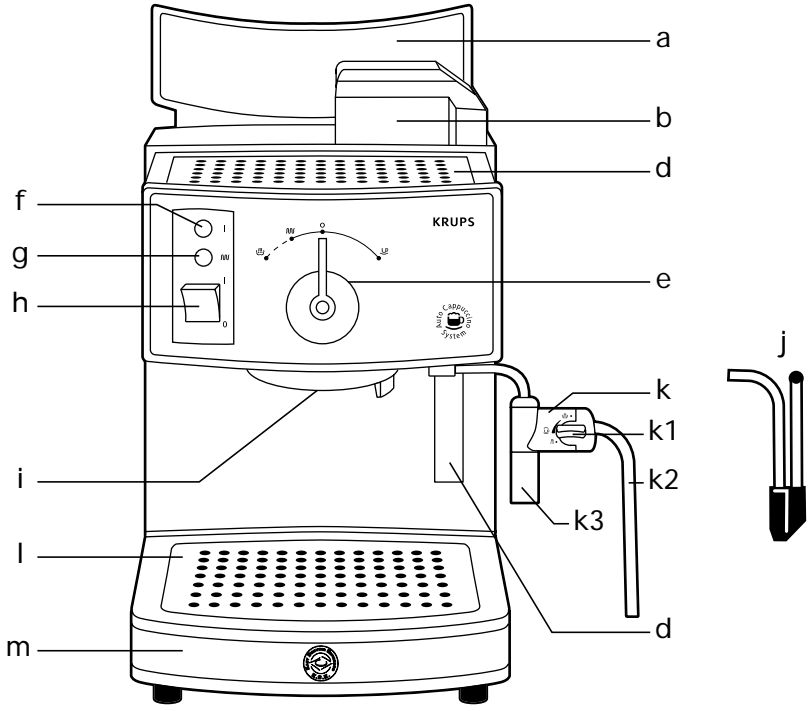
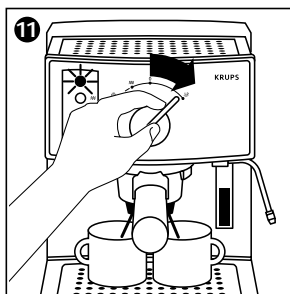
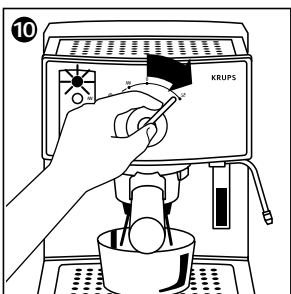
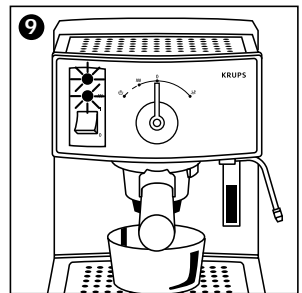
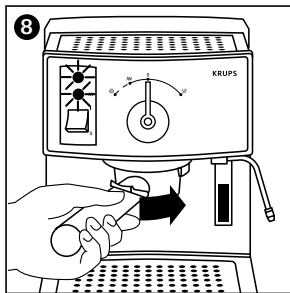
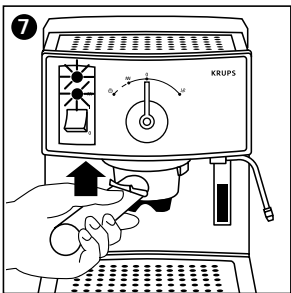
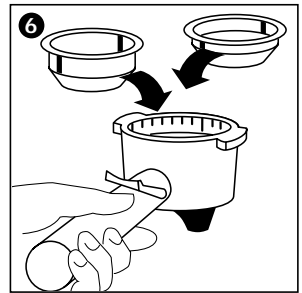
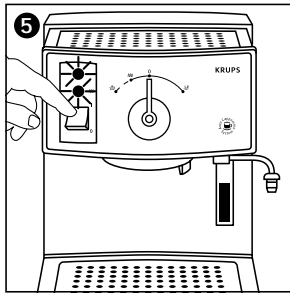
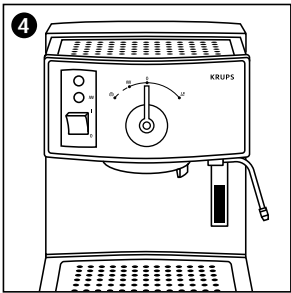
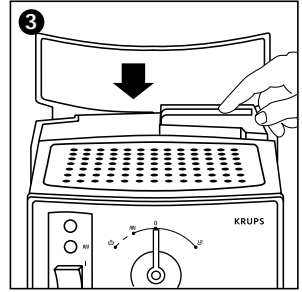
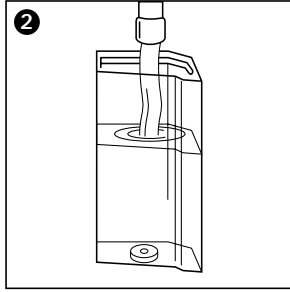
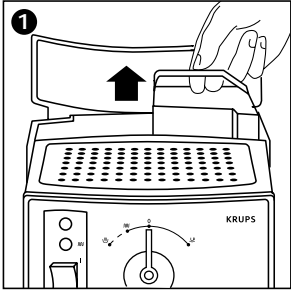
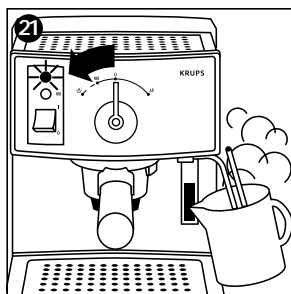
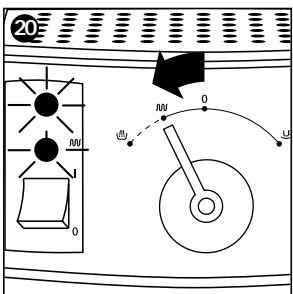
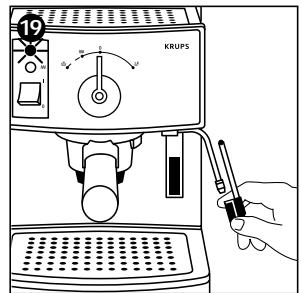
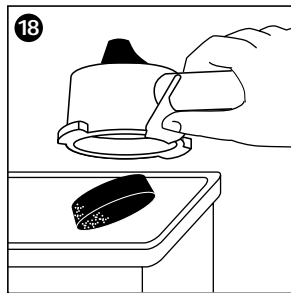
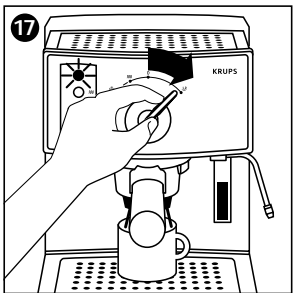
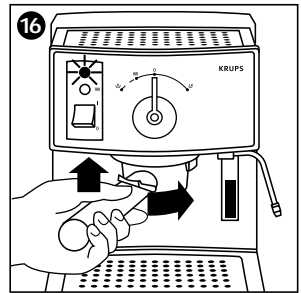
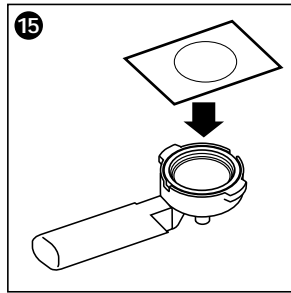
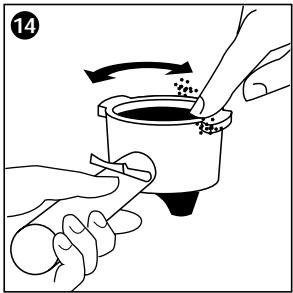
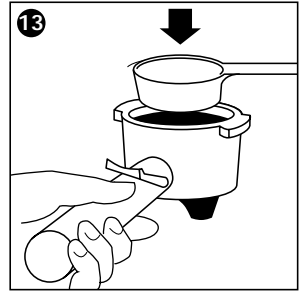
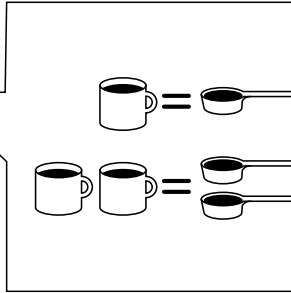
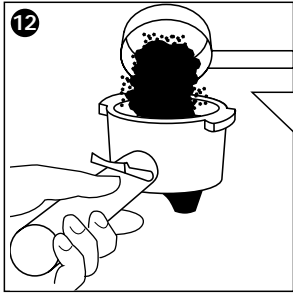

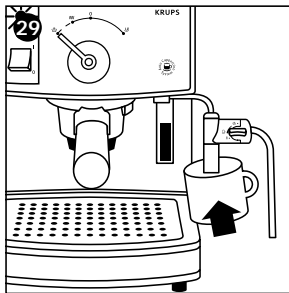
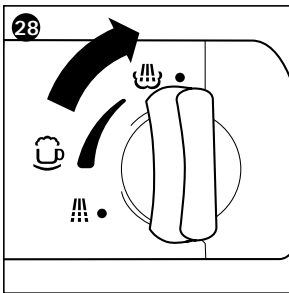
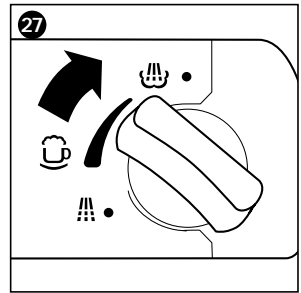
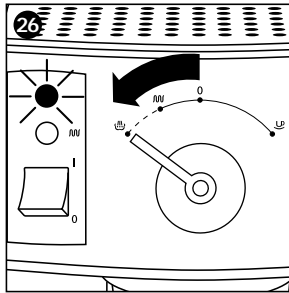
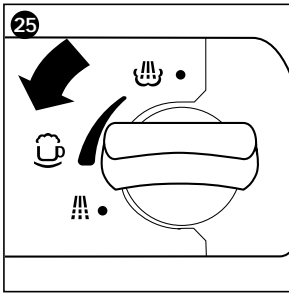
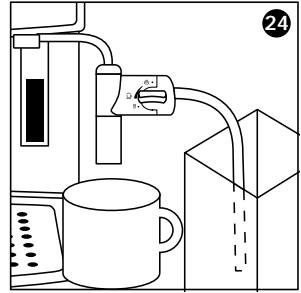
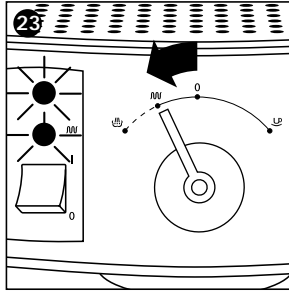
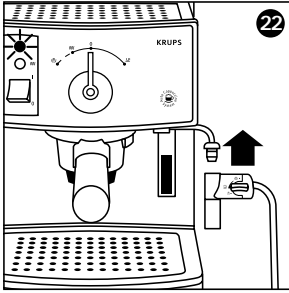

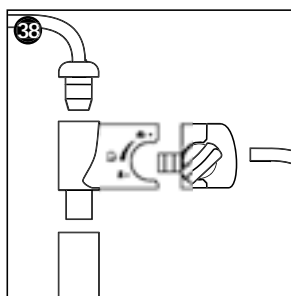
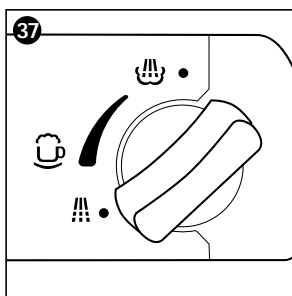
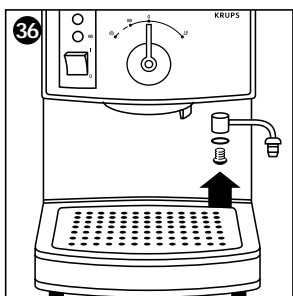
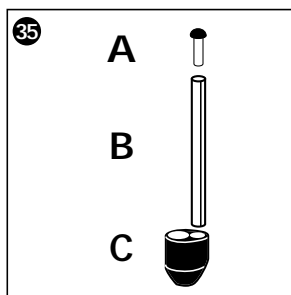
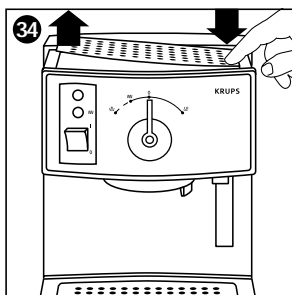
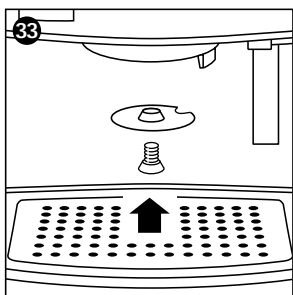
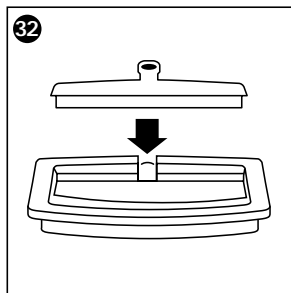
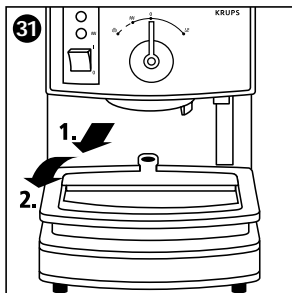
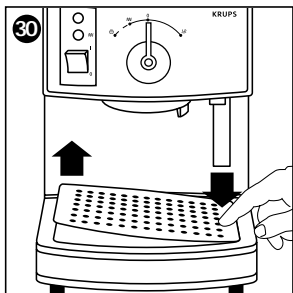

# KRUPS

Novo 3000

FNC2

Novo 3000 Premium

FNC3

## USA

---

8

Instructions for Use  
Warranty  
Guarantee of Performance

## Français

---

19

Mode d'emploi  
Garantie  
Garantie de rendement

## Español

---

30

Instrucciones de uso  
Garantía  
Garantía de rendimiento

# IMPORTANT SAFEGUARDS

When using electrical appliances, basic safety precautions should always be followed to reduce the risk of fire, electric shock and/or injury to persons, including the following:

- Read all instructions.
- Do not touch hot surfaces. Use handles or knobs.
- To protect against fire, electric shock and injury to persons, do not immerse cord, plugs, or appliance in water or other liquid.
- Close supervision is necessary when any appliance is used by or near children.
- Unplug from outlet when not in use and before cleaning. Allow to cool before putting on or taking off parts, and before cleaning the appliance.
- Do not operate any appliance with a damaged cord or plug or after the appliance malfunctions, or has been damaged in any manner. Return appliance to your nearest authorized KRUPS Service Center for examination, repair or adjustment (see Guarantee of Performance).
- The use of accessory attachments not recommended by KRUPS may result in fire, electric shock or injury to persons.
- Do not use outdoors.
- Do not let cord hang over edge of table or counter, or touch hot surfaces.
- Do not place on or near a hot gas or electric burner, or in a heated oven.
- To disconnect, turn switch to "OFF", then remove plug from wall outlet.
- Do not use appliance for other than intended use.
- Use extreme caution when dispensing hot steam.

## SAVE THESE INSTRUCTIONS



# CAUTION

- This appliance is for household use only. Any servicing other than routine cleaning and user maintenance should be performed by authorized KRUPS service personnel only (see Guarantee of Performance).
- Do not immerse base in water.
- To reduce the risk of fire or electric shock, do not remove the base of the machine. There are no user serviceable parts inside. Repairs should be performed by authorized KRUPS service personnel only.

## SPECIAL CORD SET INSTRUCTIONS

Regarding your Cord Set:

- A. A short power-supply cord is to be provided to reduce risks resulting from becoming entangled in or tripping over a longer cord.
- B. Longer extension cords are available and may be used if care is exercised in their use.
- C. If a long extension cord is used, (1) the marked electrical rating of the extension cord should be at least as great as the electrical rating of the appliance, (2) the longer cord should be arranged so that it will not drape over the counter top or table top where it can be pulled on by children or tripped over.
- D. This appliance has a polarized plug (one blade is wider than the other). To reduce the risk of electric shock, this plug is intended to fit into a polarized outlet only one way. If the plug does not fit fully in the outlet, reverse the plug. If it still does not fit, contact a qualified electrician. Do not attempt to modify the plug in any way.

## Description

<b>a</b>	Lid
<b>b</b>	Removable water container
<b>c</b>	Water level indicator
<b>d</b>	Warming plate for cups
<b>e</b>	Control selector
<b>f</b>	On/Off indicator light (red)
<b>g</b>	Temperature control light (orange)
<b>h</b>	On/Off switch
<b>i</b>	Brewing head
<b>j</b>	Steam nozzle
<b>k</b>	Auto cappuccino accessory
	K1 dial
	K2 flexible tube
	K3 outlet nozzle
<b>l</b>	Removable overflow grid
<b>m</b>	Removable drip tray
<b>n</b>	Measuring spoon
<b>o</b>	Filter baskets for one or two cups
<b>p</b>	Filter holder for ground coffee
<b>q</b>	ESE filter holder and filter system

## Safety recommendations

- Read these instructions carefully before using your espresso machine.
- Do not plug the machine into anything other than a grounded electrical socket. Verify that the voltage indicated on the technical specifications plate on the bottom of the unit corresponds to your electrical installation.
- Do not place your espresso machine on a hot surface (an electrical heating plate for example) or near a flame.
- Do not use the machine without the drip tray and drip tray grid in place.
- Unplug the machine while cleaning.
- Ensure that the electrical cord does not come into contact with sharp or hot objects. Do not disconnect the electrical plug by pulling on the cord.

- Avoid touching the electrical cord as well as any other part which may become hot during the use of the machine (steam nozzle).
- Never plunge the machine in water.
- Keep the machine and the electrical cord out of children's reach.
- For descaling, adhere to the directions which follow.
- Do not use the machine if it is damaged or if the cord is in bad condition.
- The cord or any other defective element must be replaced exclusively by an authorized Krups service center. Under no circumstances should you open the machine yourself.

## Espresso coffee

Your new Krups espresso machine has been constructed to make cafe quality espresso, cappuccino and latte at home. Espresso coffee is richer in aroma and stronger than normal coffee. It is drunk from small pre-heated espresso cups. Hot water is passed through the ground coffee to obtain this delicious foamy, black coffee, which has an invigorating effect.

You can recognize an espresso by its characteristic aroma and its typical light brown "crema" found on top of the coffee. But this requires high pressure and an excellent espresso coffee which has been well roasted and correctly ground. If you cannot buy ground espresso coffee, use a coffee grinder to grind the beans. The coffee must not be ground too fine. It must be slightly granulated. If it is too fine, you risk blocking the grid of the brewing head and the filter.

To guarantee complete success for your espresso, you must also use freshly-drawn water (so that it has not had time to stagnate in the air), without any chlorine odor and at a fairly cold temperature.

## Before first using your machine

Before using your appliance for the first time, clean the water heating system (without coffee in the filter holder and filling the water container once or twice) as follows:

- Open the lid and lift out the water container using the handle **(1)**. Fill the water container with fresh, cold water **(2)**.
- Replace the water container back into the appliance by positioning it firmly in the water container compartment **(3)** and close the lid.

The water level in the water container can be checked at any time using the window provided for this purpose, so if necessary you can add more water **(4)**.

- Turn on the appliance **(5)**. The red operating light and the orange temperature control indicator light will both come on.
- Place one of the filter baskets in the filter holder **(6)**. Then put the filter holder up against the appliance's brewing head.
- To ensure that the filter holder is in the correct position, turn the handle so it points to the left at a 45 degree angle **(6)**, place the filter holder flat against the brewing head, then turn the handle towards the right **(7)** as far as it can go **(8)**.
- Place a container, as large as possible, beneath the filter holder **(9)**.
- As soon as the orange indicator light goes off, turn the selector to the **☺** setting **(10)** and allow all the water in the water container to run through.
- If necessary, you can stop the operation by turning the selector to the **O** setting to empty the container, then resume operation.

## Using the various functions of your espresso machine

### 1. ESPRESSO FUNCTION

#### • WITH GROUND COFFEE

For best results, we recommend that you first **pre-heat the accessories** (filter holder, filter basket and cups) **without putting in ground coffee**. To do this :

- Fill the water container with fresh, cold water **(1) (2) (3)** and turn on the appliance **(5)**. **Empty the cups.**
- Put the filter holder and an empty filter basket in place **(6) (7) (8)**, and place the espresso cups underneath.

- As soon as the appliance reaches the correct temperature the orange indicator light will go out.
- Turn selector to the **☺** setting **(10)**.
- When the cups are full of hot water, reset the selector to the **O** setting.

After making your first espresso and the appliance is hot, the espresso cups can then be pre-heated on the cup warming plate.

#### • Preparing an espresso :

- Fill the water container **(1) (2) (3)** and turn on the appliance **(5)**.
- Put the filter basket for one or two cups into the filter holder **(6)** .
- Place some ground coffee in the filter basket (1 or 2 measuring scoops), and then tamp it down firmly; the coffee should reach the lip of the filter **(12) (13)**.
- Remove any ground coffee which is lying around the filter **(14)**.
- Replace the filter holder into the machine. Turn the filter holder until it is firmly locked into place. **(16)**.
- Place one or two espresso cups beneath the filter holder.

As soon as the appliance reaches the correct temperature the orange indicator light will go out.

- Then turn the selector to the **☺** setting **(17)**.
- When the cups are full, reset the selector to the **O** setting.
- Remove the filter holder and the filter from the machine, and take out the coffee grounds **(18)**.

The filter basket can be refilled to make more espressos.

**Caution: if the water container is empty and the pump is running, you will hear a very distinct noise, which is louder than the normal operating sound. If this happens, turn the machine "off". Check the water container and refill as needed.**

**Never let the pump run when the water container is empty as this can damage the pump.**

If you are preparing more than one cup of espresso, disregard the orange thermostat light. It simply indicates that the thermostat is regulating the temperature.

### **ESPRESSO FUNCTION WITH THE SPECIAL “ ESE ” FILTER HOLDER**

“ESE”, which stands for “Easy Serving Espresso”, is a selected measure of coffee, ground and pressed between two filter papers making a coffee pod which is ready to use (for example “illy® pods”). This system makes it easy for you to prepare your espresso and to clean the appliance.

The E.S.E. system was designed for making Italian-style “espresso ristretto” or “short espresso”. The amount of coffee is about two ounce and the water should take 20 seconds to run through.

**We do not intend, or recommend, that the ESE servings are used for making a “long espresso”.**

We recommend that you take care when handling and storing the ESE servings so that they do not become deformed.

For best results, we recommend that you pre-heat the accessories (filter holder, filter basket and cups) without any coffee. To do this:

- Fill the water container with fresh, cold water **(1) (2) (3)** and turn on the appliance **(5)**.
- Put the empty ESE filter in place **(7) (8) (9)** and position the espresso cup underneath.

Once the appliance reaches the correct temperature, the orange temperature control light will go out.

- Then turn the selector to the  setting **(10)**.
- When the cup is full of hot water, reset the selector to the **O** setting.

Once the machine has heated up, the espresso cups can be pre-heated on the cup warming plate (on top of the machine).

#### **. Preparing an espresso:**

Place the serving of “illy® in the ESE filter holder fitted with its own filter. The wording “illy® must be pointing towards the bottom.

#### **Setting the ESE pod**

Placing the ESE pod correctly will create a richer, thicker crema.

Tear excess paper from pod at perforated edge. Place the ESE pod with the RED MARKING FACE DOWN (bend the paper corners down).

LOCKING the handle TIGHTLY and PROPERLY will avoid leakage from the filter holder and ensure a better brewing cycle.

Place the filter holder inside the brewing head and FIRMLY turn the handle as far RIGHT as possible.

Once the appliance reaches the correct temperature, the orange temperature control light will go out.

- Then turn the selector to the setting  **(10)**.
- When the recommended quantity of coffee has been reached (about two ounce) turn the selector to the **O** position.

Remove the ESE filter holder from the brewing head and throw away the used coffee pod.

NOTE: Other pods (such as those sold by Starbucks®) can be used in your Krups Novo 3000 & 3000 Premium as long as they are E.S.E. standard pods.

illy® is a registered trademark of illy espresso of the americas, inc.

Starbucks® is a registered trademark of the Starbucks Coffee Company.

## **2. STEAM FUNCTION FOR PREPARING CAPPUCCINO AND LATTE**

The thumping noise which occurs while steam is being produced comes from the intermittent regulation of the pump and has no effect on the proper working of the appliance.

If you wish to make an espresso immediately after using the steam function, the appliance must first be allowed to cool down in order to achieve the correct temperature for preparing an espresso.

- To do this, place a container below the filter holder (without coffee) and position correctly, then turn the selector to the  setting **(10)**.
- Allow the water to flow through until the orange indicator light comes on. Then turn the selector to the **O** setting.

After this, you can make another espresso.

**Caution:** during and after use of the machine, the metallic parts of the steam nozzle can become burning hot.

### . Using the Krups Auto Cappuccino accessory (model FNC3 only)

The Auto-Cappuccino accessory makes it easy to produce frothy milk for making cappuccinos, lattes and hot chocolates.

#### **The milk is drawn in through the flexible tube and heated with the aid of steam before coming out via the outlet nozzle of the auto cappuccino accessory.**

If the flexible tube is immersed directly in a carton of milk, a single cup is enough to prepare a cappuccino or a latte. You can adjust the amount of froth of the milk by using the dial of this auto cappuccino accessory.

It is best to use fresh, skim or low-fat milk, not boiled, and well chilled (kept in the refrigerator). The container must also be cold (do not run it under hot water before frothing the milk).

For heating thick liquids, please refer to the section "Heating thick liquids (e.g. soup)"

We recommend that you clean the auto cappuccino accessory immediately after use - please refer to section "Cleaning the Machine".

If you are making a cappuccino or latte, you will need at least a 5 oz. cup (150 ml).

Cappuccino is made using 1/3 espresso, 1/3 hot steamed milk and 1/3 frothed milk. Café latte is made using 1/2 espresso, 1/2 steamed milk, and topped with a bit of frothy milk.

- Fill the water container with fresh, cold water **(1) (2) (3)** and turn on the appliance **(5)**.
- Move the nozzle to the exterior of the appliance and mount the auto cappuccino accessory on the nozzle **(22)**.
- Turn the dial to the  setting **(23)**.
- Immerse the flexible tube in the milk to be heated (you can use the Krups container or any other container) **(24)**.

Once the appliance reaches the right temperature, the orange temperature control light will go out.

- Hold the container under the steam nozzle equipped with the cappuccino accessory in such a way that the tip is immersed in the milk.
- Turn the selector to the  setting **(26)**. Keep the container straight during this operation. Do not allow the tip of the nozzle to touch the bottom of the container because this could obstruct the steam output.
- Once you have obtained the desired quantity of frothy milk, turn the selector to the **O** setting.
- After use, remove the flexible tube from the container and clean the auto cappuccino accessory (see section "Cleaning the Machine").

### . Preparing hot, steamed milk for a cafe latte, hot chocolate or for heating water (for tea, for example).

#### **Notes:**

. Hot chocolate: immerse the flexible tube directly into the carton if the chocolate milk is ready-made, or heat the milk if you are using powdered chocolate. Then mix the powder in the heated milk.

- Move the nozzle to the exterior of the appliance and mount the auto cappuccino accessory on the nozzle **(19)**.
- Fill the water container **(1) (2) (3)** and turn on the appliance **(5)**.
- Turn the selector to the setting  **(20)** .
- Turn the dial of the auto cappuccino accessory to the fine end of the setting scale **(27)**.
- Immerse the flexible tube in the liquid to be heated. The tube must touch the bottom of the container.
- Place a container under the outlet nozzle.

Once the appliance reaches the right temperature, the orange temperature control light will go out.

- Turn the selector to the steam setting  **(21)**.
- Once you have obtained the desired quantity of frothy milk, turn the selector to the **O** setting.

- After use, remove the flexible tube from the container.



### . Using the Krups patented Perfect Froth Attachment

Krups patented Perfect Froth attachment is available on all models. For the FNC3 model you will need to remove the auto-cappuccino attachment and replace it by the Perfect Froth Attachment in order to execute this operation **(36)**.

You can use the Perfect Froth attachment to froth milk for cappuccinos, Lattes and hot chocolates as well as heating any liquid (water for tea or thick liquids for soups)

- Fill the water container **(1) (2) (3)** and start the appliance **(5)**.
- Move the steam nozzle to the exterior of the appliance.
- Turn the selector to the setting  **(20)**.

Once the appliance reaches the correct temperature, the orange temperature control light will go out.

- Immerse the steam nozzle in the container holding the liquid to be heated.
- Then turn the selector to the  setting **(21)** until the liquid is hot enough, then reset the selector to the **O** setting and remove the container.
- For liquids other than water, turn the selector to the setting  **(20)** for the following cleaning operation in order to prevent any blockage of the opening of the steam nozzle :
  - place an empty container below the steam nozzle.
  - select the  setting again **(21)** to remove the residue of the liquid.
  - turn the selector to the setting **O**.
  - Clean the steam nozzle with a damp cloth.
  - For more thorough cleaning of the nozzle, please refer to the paragraph on maintenance.

## Cleaning the Machine

- Never wash your espresso machine accessories in the dishwasher.

After use, the water container must be emptied.

### . Removable drip tray

After using the appliance, remove the overflow grid and empty the removable drip tray **(30) (31)**. If several espressos are being prepared one after the other, the drip tray should be emptied from time to time (about once every 7 - 8 espressos). If necessary, clean the drip tray and its grid with water and a little non-abrasive dishwashing liquid, rinse and dry. When reassembling the machine, ensure that the plastic lining is in the right place **(32)**.

### . The brewing head, the filter basket and the filter holder

These must be cleaned after each use. All you need to do is wipe a damp cloth over the brewing head of your appliance and to wash the other accessories in water and a little non-abrasive dishwashing liquid, rinse and dry.

If the brewing head is heavily clogged up, unscrew the grid using a coin, clean it and refit it, pressing down firmly **(33)**.

When your espresso machine is not being used, do not leave the filter holder in the appliance to prevent wear on the gasket.

. **The cup warming plate:** remove this to clean it with water and a little non-abrasive dishwashing liquid, rinse and dry **(34)**.

. **Steam nozzle:** wipe with a damp cloth after each use.

### . The auto cappuccino accessory

After each use, we recommend that you rinse the auto cappuccino accessory in the following manner:

- Turn the selector to the steam pre-heating position  **(19)**.
- Turn the dial to the cleaning position **(37)**.
- Immerse the flexible tube into a glass of water. (The minimum quantity necessary is 3 to 4 ounces/30-60 ml).
- Place an empty container below the outlet nozzle.

Once the appliance reaches the correct temperature, the orange temperature control light will go out.

- Then turn the selector to the steam setting **(26)**.
- When all the water has run through the

auto cappuccino accessory turn the selector to the **O** position.

- After use, remove the flexible tube from the container.
- Once this operation is completed, clean the outlet nozzle with a damp cloth.

We recommend that you regularly dismantle the auto cappuccino accessory and clean it with water, a little non-abrasive dishwashing liquid and a small brush. Rinse and dry before reassembling it **(38)**.

**Be careful to mount the flexible tube the right way:** engage the straight cut end into the auto cappuccino accessory.

### . Brewing head gasket

From time to time this gasket must be cleaned :

- Put the filter basket in the filter holder and place the filter holder in the machine.
- Place a container under the filter holder.
- Turn on the appliance.
- Turn the selector to the setting .
- When the hot water starts to filter through, turn the filter holder slowly from left to right so that the water filters through between the gasket and the filter.

## Descaling

- Descaling of your espresso machine should be done fairly frequently with citric or tartaric acid.

**The guarantee does not include espresso machines which do not function, or do not function properly, because descaling has not been carried out.**

However, we would advise you to use the **Krups descaling solution** which is available from Krups. Descaling depends on the hardness of the water, but also on the frequency of use.

- **Then follow the following method:**

- Unscrew the grid from the brewing head of the appliance and clean it.
- Dissolve 2 tsp/10 ml of the descaling product or a packet of KRUPS descaling solution, in 17 oz/510 ml of lukewarm water and pour the whole batch into the empty water container.

- Place a container under the brewing head. Run through about 1/3 of the liquid immediately, setting the selector to the position **U (10)**.
- Stop the appliance, leaving the position **(10)** engaged and wait for 10 - 15 minutes to allow the descaler to take effect.
- Next, start the machine again and allow the rest of the liquid to run through.
- Then rinse with two water containers of fresh water and replace the grid on the head of the appliance (see section on "Cleaning the Appliance").

## Problems, probable causes and how to correct them

Problems	Probable causes	Corrective actions
Espresso not hot enough	Cups, filter and filter holder are cold.	Preheat the accessories (cups, filter, filter holder) See paragraph «Preparing an espresso».
Coffee leaks around the filter holder	The filter holder is not mounted correctly or has not been tightened sufficiently.	See paragraph «Preparing an espresso».
	There are coffee grounds on the edge of the filter	Clean around the filter and the gasket.
	The brewing head gasket is dirty.	Clean the gasket with a damp cloth.
	The brewing head gasket is defective	Contact an approved Krups service centre.
Pump is very noisy	No water in the water tank.	Fill the water tank.
	Water tank incorrectly mounted.	Press firmly down on the water tank.
	Coffee grounds too old or very dry and the pump cannot produce pressure.	Use fresh coffee

Water does not run through	No water in the water tank. Water tank incorrectly mounted.	Fill the water tank. Press firmly down on the water tank.
	The filter is blocked, the coffee grounds are too fine or tamped down too hard.	Clean the filter and the grid on the head. See the paragraph «Maintenance» and try a coarser coffee.
	Brewing head grid is encrusted	Put the grid to soak in descaling solution See paragraph «Maintenance».
	Appliance needs descaling.	See paragraph «Descaling».
Water runs through too quickly	Coffee grounds too coarse	Try a finer coffee
	Quantity of ground coffee is insufficient.	Use the spoon provided to measure out the coffee.
	Coffee grounds not tamped down firmly enough	Tamp down the coffee again.
The espresso has no froth (crema on coffee)	Coffee grounds too coarse	Try a finer-ground coffee
	Coffee grounds not tamped	Tamp down the coffee again
	Coffee grounds stale or too dry	Use fresh coffee
The milk is not very frothy	Steam nozzle blocked	See paragraph «Maintenance»
	Cappuccino accessory blocked	See paragraph «Maintenance»
	Milk not fresh.	Use fresh milk
	Milk is lukewarm.	Put milk in refrigerator.
Lots of water on the coffee grounds	Grounds not properly tamped down	Tamp down the grounds
	Insufficient quantity of ground coffee	Increase the quantity of ground coffee.

## Recipes

Savor your espresso just as you like it: when you want to relax or to top off a good meal. Here are a few recipes which you will be able to create with your espresso machine.

### . Original espresso

- Take one measuring spoonful of good quality well roasted espresso coffee, and make an espresso directly into a pre-heated cup.

If you use good, finely ground coffee, the cup will be crowned by a fine head of golden froth (crema).

- Add sugar if desired and enjoy.

### . Cappuccino

For a state of the art cappuccino, the ideal quantities are as follows: 1/3 coffee, 1/3 hot, steamed milk, 1/3 frothy milk.

- Use 5 oz. cups/150 ml which have been pre-heated.
- Fill them with 1/3 espresso coffee. Using the auto cappuccino accessory, fill the cup with another 1/3 of steamed milk and 1/3 of froth.
- Lastly, sprinkle with drinking chocolate powder or cinnamon.

### . Cafe latte

For a state of the art latte, the ideal quantities are as follows: 1/2 coffee, 1/2 hot, steamed milk topped with some frothed milk.

- Prepare a classic espresso in a large cup.
- Add steamed milk.
- Top with some froth.

### . Iced coffee à l'italienne

4 vanilla ice cubes, 2 cups of cold, sweetened espresso, 4 ounces milk, fresh cream, grated chocolate.

- Mix the cold espresso with milk.
- Distribute the ice cubes among the glasses, pour the coffee over them and decorate with fresh cream and grated chocolate.

### . Friesian coffee

- Add a small glass of rum to a sweetened cup of espresso.



- Top with a good layer of fresh cream and serve.

## Limited One Year Warranty

Your KRUPS # FNC2/FNC3 is covered by the following warranty :

If within one year from date of purchase this KRUPS product fails to function because of defects in materials or workmanship, KRUPS North America will, at its option, repair or replace the unit without charge, provided the owner has a proof of date of purchase.

This warranty will be void if malfunction was caused by damage to the product by accident, misuse, use on frequency or voltage other than marked on the product and/or described in the instructions, abuse including tampering, damage in transit, or use for commercial purposes. This warranty gives you specific legal rights, and you may also have other rights which may vary from state to state.