

Age Range: 1-1/2 - 6 Yrs.
 Weight Limit: 50 Lbs.
 Surfaces: Hard
 Speed: 2.5 MPH
 Colors: White Body
 Black Wheels
 Red & Yellow Trim

Intro: 1993
 Suggested Retail \$159.99
 Warranty 90 Vehicle
 6 Months Battery

76115-9993 / 84520 'CYCLE SOUND PRO 250

Preschool Series
 6-VOLT

2 AA Batteries Required for Sound Box

SERVICE BULLETIN 140

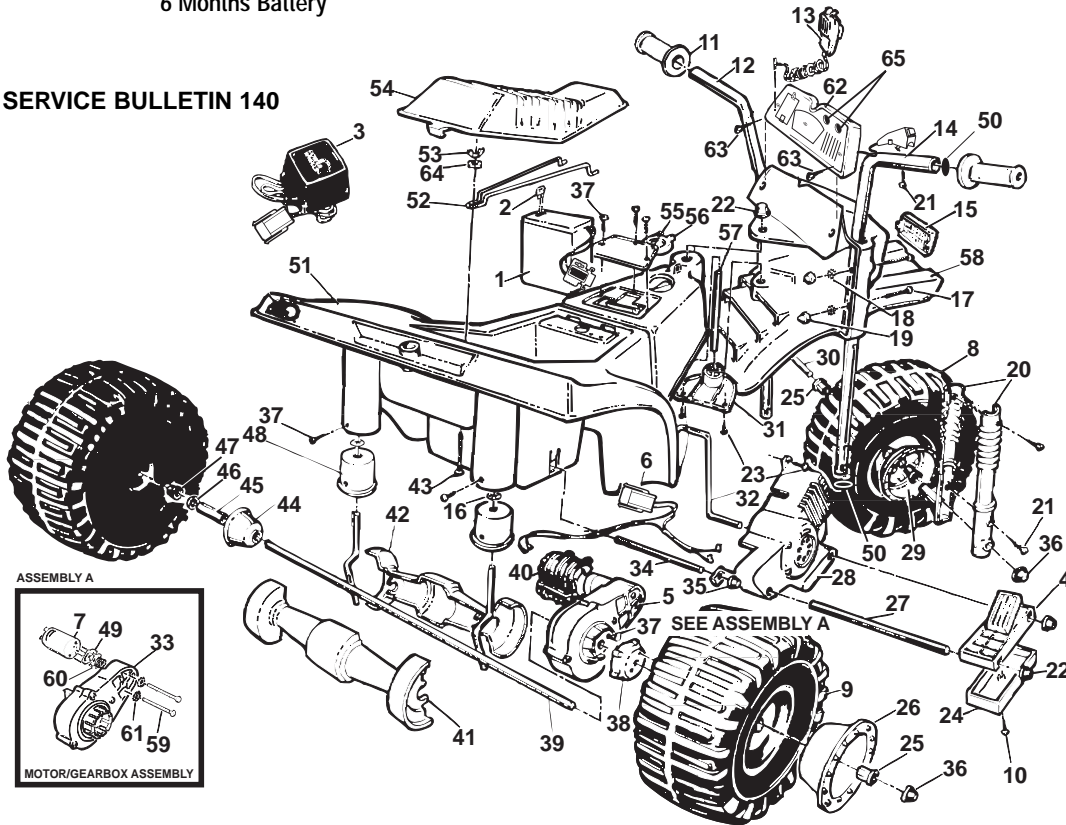

REV. 09/18/03

Item No.	Description	Part No.	Qty.	Item No.	Description	Part No.	Qty.	Item No.	Description	Part No.	Qty.
1	Battery, Type H	00801-1234	1	26	Rear Hubcap	74590-2579	2	49	D Lock Washer	0801-0329	1
2	25 amp Fuse	0801-0151	1	27	Support Rod			50	Handlebar Cap Plugs N/A	74510-2169	4
3	Charger, 6-Volt	00801-0975	1		(Rear Foot Rest) (N/A)	76108-4439	1	51	Body (N/A)	80005-0231	1
4	Footswitch Assy.	76108-9159	1	28	Right False Motor (N/A)	76116-2139	1	52	Battery Retainer N/A	76112-4419	1
5	Motor/Gearbox Assy N/A	74510-9519	1	29	Front Hubcap	73233-2579	2	53	Wing Nut N/A	0801-0317	1
<u>6</u>	<u>Wiring Harness N/A</u>	<u>76112-9799</u>	<u>1</u>	30	Front Axle (N/A)	80025-0006	1	54	Seat N/A	76115-2819	1
<u>7</u>	<u>Motor 6-Volt N/A</u>	<u>74510-0640</u>	<u>1</u>	31	*Flex Plate N/A	74510-2159	1	55	Cov Panl Switch Plate N/A	76115-2349	1
8	Front Wheel N/A	76266-2459	1	32	False Motor Suppt N/A	80021-0074	1	56	Gas Cap N/A	76115-2249	1
9	Rear Wheel N/A	76188-2459	2	<u>33</u>	<u>Gearbox</u>	<u>74580-9269</u>	<u>1</u>	57	Pivot Pin N/A	76108-4429	1
10	#8 x 2" Plascrew N/A	0801-0268	1	<u>34</u>	<u>Supprt Rod Rear Motor N/A</u>	<u>76108-2129</u>	<u>1</u>	58	* Fender/Headlight N/A	80022-0033	1
11	Handgrip N/A	76115-2179	2	35	.250 Retainer N/A	0801-0322	2	<u>59</u>	<u>Motor Bolts</u>	<u>0801-0269</u>	<u>2</u>
12	Left Handlebar (N/A)	80029-0052	1	36	.437 Cap Nut	0801-0226	4	<u>60</u>	<u>Motor Drive Gear</u>	<u>74550-2269</u>	<u>1</u>
13	Microphone/Cord Assy.	74550-9479	1	37	#10 x 1/2" Screw	0801-0255	6	<u>61</u>	<u>Star Washer N/A</u>	<u>0801-0330</u>	<u>2</u>
14	Right Handlebar (N/A)	80029-0053	1	38	Driver	73233-2239	1	62	Sound Box/Trigger N/A	76115-9459	1
15	Headlight Lens N/A	76112-2129	1	39	Rear Axle Assy (includes #48) (N/A)	80046-0169	1	63	#8 x 1-1/2" Screw	0801-0308	2
16	354 Retain w/out Body N/A	0801-0252	2	40	Motor Cover	74750-2359	1	64	#10 Washer N/A	76822-4409	1
17	1-1/4" 10-32 Screw	76125-4459	4	41	Axle Cover (Outside) N/A	76115-2169	1	65	Radio Knobs N/A	76115-2189	2
<u>18</u>	<u>Star Washer N/A</u>	<u>76108-4419</u>	<u>4</u>	42	Axle Cover (Inside) N/A	76115-2159	1				
19	Acorn Nut N/A	0801-0218	4	43	Carriage Bolt N/A	0801-0305	1				
20	*Shock Set N/A	76115-2339	2	44	Hubcap w/o Shoulder	76108-2369	1				
21	#8 x 3/4" Plascrew	0801-0223	5	45	Spacer N/A	76112-2139	1				
22	.354 Cap Nut	0801-0604	6	46	Washer	0801-0196	2				
23	#8 x 1/2" Plascrew	0801-0202	5	47	Wheel Bushing	74550-2689	1				
24	Bottom Cover (Footboard) N/A	76108-2169	1	48	Axle Bushing (N/A)	76092-2549	2				
25	Hex Bushing N/A	73233-2559	4								

PARTS NOT SHOWN

Left False Motor (N/A)	76115-2149	1
Left Footrest N/A	76108-2179	1
Decal Sheet (N/A)	80017-0218	1
Literature Bag N/A	80034-0473	1

*See Service Bulletin 140

N/A = Not Available

Bold and Underlined parts are to be purchased and installed by Service Centers only. These items may not be sold directly to consumers by Service Centers or Fisher-Price.

