

Age Range: 6 and up
 Weight Limit: 150 lbs.
 Surfaces: Hard surface/ Grass
 Speed: 7 mph
 Colors: Green/silver/black
 Intro: 2003
 Suggested Retail: \$199.99
 Box Dimensions: 21.75 x 10.62 X 35.75
 54.3 lbs
 Warranty: One Year Vehicle
 6 Months Battery

73535 & G4647

B2222 & G4882 Canada

Minibike

**73535 May Be Under Recall.
Please Confirm That Product
is Modified Or Remediated
In Accordance With Recall
Policy.**

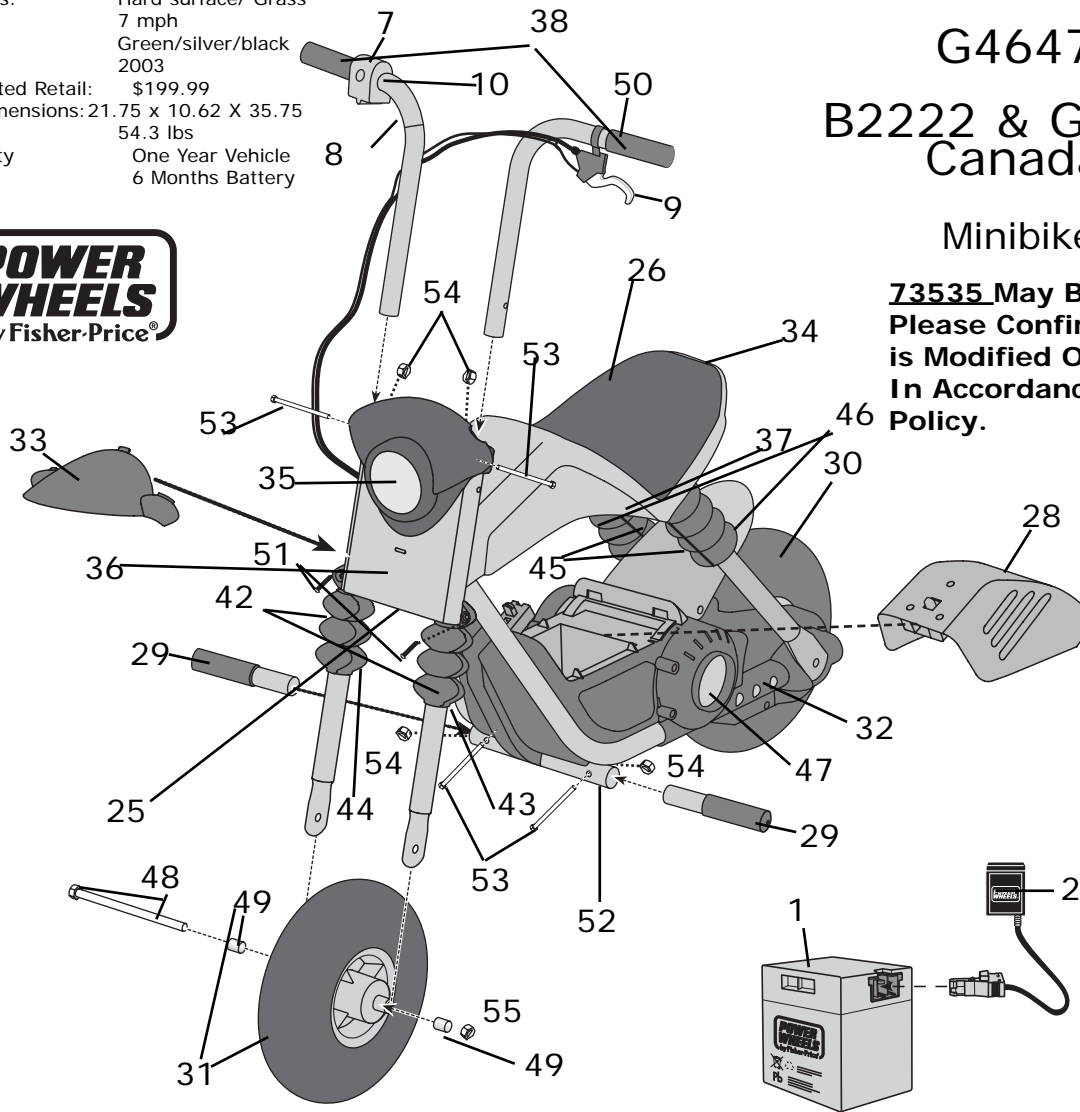

Rev. 8/3/05

Item No.	Description	Part No.	Qty. Item	Part	No. Qty.	Description	No.
Working / Electrical Parts							
1.	*Battery 12V 9.5 Amp (Use 12V 12 Amp As Replacement)	00801-0638	1				
2.	Charger w/Probe	00801-0972	1				
3.	Motor w/Idler Pulley	00968-9006	1				
6.	Battery Harness Assembly	73535-9559	1				
7.	Turbo switch	73535-9549	1				
8.	Handlebar Throttle Tube N/A/73535-4029		1				
9.	Brake	73530-9119	1				
10.	Assembly Turbo Throttle w/hand grips	73535-9029	1				
Hardware / Metal Parts							
37.	Tank Cover minus seat	73535-2629	1				
38.	Hand Grips N/A (See 10 & 50)		2	73530-2239			
42.	Front Shocks Outer (L & R)	73535-2449	2				
43.	Left Front Shock Rear	73535-2439	1				
44.	Right Front Shock Rear	73535-2459	1				
45.	Back Rear Shock-Inner	73535-2649	2				
46.	Back Rear Shock Outer	73535-2659	2				
47.	Reflector/Housing N/A	N/A	2				
48.	Front Axle w/(1) Nyloc Nut	73535-4499	1				
49.	Spacer (Ord front wheel assembly)		2				
50.	Handlebar brake tube w/hand grips	73535-9339	1				
51.	8 X 1 Screw	0912-8003	2				
52.	Footpeg tube-(metal)	73535-4469	2				
53.	1/4-20 x 1-1/2-1-9/16 Bolt N/A/73535-4489 (order parts bag-73535-9069)		4				
54.	1/4-20 7/16 Nyloc-Nut N/A (order parts bag-73535-9069)		4	73530-4449			
55.	1/2-13 Nyloc Nut (9/16)	73535-4479	1				
Plastic / Other Parts							
25.	Body	N/A					
26.	Seat Assm.	73535-9639	1				
28.	Battery Cover Assembly	73535-9329	1				
29.	Foot Pegs	73535-2619	2				
30.	Rear Wheel Assm.	73535-9349	1				
31.	Front Wheel Assm (includes spacers (bushings))	73535-9249	1				
32.	Brake Guard	73535-2789	1				
33.	Front Fender	73535-2429	1				
34.	Rear-Reflector N/A	73530-2399	1				
35.	Headlight Assembly	73535-9419	1				
36.	Front Fork	73535-4079	1				
Parts Not Shown							
	Parts Bag	73535-9069	1				
	Literature Bag	73535-9019	1				
	Owners Manual (Order Lit bag)		1				
	Decal Sheet	73535-0310	1				
	Allen Wrench 5 MM	73535-4069	1				
	Plastic Tie (Order Lit Bag)		1				
	PC Board	73535-9539	1				
	Tire Tube-Rear	73530-2359	1				
	Drive Belt	73530-2289	1				
	Tire Tube-Front	73530-2259	1				
	PIC Switch-push button	00801-1198	1				
	Head Tube-Sleeve	73535-4459	1				
	Head Tube Bushing	73535-2609	2				
	Brake Assembly	73530-9259	1				
	Rear Axle	73535-4099	1s				

N/A = Not Available *Produced w/either 12V, 9.5 amp or 12V, 12 amp battery. Use 12V, 12 amp as replacement battery.

Bold and Underlined parts are to be purchased and installed by Service Centers only. These items may not be sold directly to consumers by Service Centers or Fisher-Price.