

KRUPS

DuotheK Plus

Model #464



Instructions
for Use

Warranty

Guarantee of
Performance

IMPORTANT SAFEGUARDS

When using electrical appliances, basic safety precautions should always be followed to reduce the risk of fire, electric shock, and/or injury to persons, including the following:

- Read all instructions and information in this instruction book and any other literature included in this carton referring to this product before operating or using this appliance.
- Do not touch hot surfaces. Use handles or knobs.
- To protect against electric shock, do not immerse cord, plugs, or appliance in water or other liquid.
- Close supervision is necessary when any appliance is used by or near children.
- Unplug from outlet when not in use and before cleaning. Allow to cool before putting on or taking off parts, and before cleaning the appliance.
- Do not operate any appliance with a damaged cord or plug or after the appliance malfunctions, or has been damaged in any manner. Return appliance to your nearest authorized KRUPS service center for examination, repair or adjustment.
(see Guarantee of Performance)
- The use of an accessory not evaluated for use with this appliance may cause injuries.
- Do not use outdoors.
- Do not let cord hang over edge of table or counter, or touch hot surfaces.
- Do not place on or near a hot gas or electric burner, or in a heated oven.
- To disconnect, turn switch to "OFF", then remove plug from wall outlet.

- Do not use appliance for other than intended use.
- Snap lid securely onto glass carafe before serving beverages.
- Do not remove glass carafe from heating plate while water is dripping from the spout.
- Appliance with glass carafe:
 - A. The carafe is designed for use with these appliances.
It must never be used on a range top.
 - B. Do not set a hot carafe on a wet or cold surface.
 - C. Do not use a cracked carafe or a carafe having a loose or weakened handle.
 - D. Do not clean carafe with rough cleansers, steel wool pads, or other abrasive material.

SAVE THESE INSTRUCTIONS

CAUTION

This appliance is for household use. Any servicing other than cleaning and user maintenance should be performed by an authorized KRUPS service representative. (see Guarantee of Performance)

Do not immerse base in water or any other liquid.

To reduce the risk of fire or electric shock, do not remove the base. No user serviceable parts inside. Repair should be done by authorized service personnel only.

- Check voltage to be sure that the voltage indicated on the name plate agrees with your voltage.
- Never use warm or hot water to fill the water container! Use cold water only!
- Never refill the water chamber while this KRUPS coffee maker is in operation, in the "on" position. Turn the KRUPS coffee maker off and let cool down for 10 minutes before refilling with water.
- Before turning your KRUPS coffee maker on, please make sure that:
 1. the filter is properly inserted into the swivel filter;
 2. the swivel filter is properly closed;
 3. the lid for the glass carafe is properly attached to the glass carafe;
 4. the glass carafe sits flat on the inside circle of the heating plate.
- Keep your hands and the cord away from hot parts of the appliance during operation.
- Never clean with scouring powders or hard implements.

SPECIAL CORD SET INSTRUCTIONS

Regarding your Cord Set:

- A. A short power-supply cord is provided to reduce risks resulting from becoming entangled in or tripping over a longer cord.**
- B. Longer extension cords may be used if care is exercised in their use.**
- C. If a long extension cord is used, (1) the marked electrical rating of the extension cord should be at least as great as the electrical rating of the appliance, (2) if the appliance is of the grounded type, the extension cord should be a grounding-type 3-wire cord, and (3) the longer cord should be arranged so that it will not drape over the counter top or table top where it can be pulled on by children or tripped over.**
- D. This appliance has a polarized plug (one blade is wider than the other). To reduce the risk of electric shock, this plug is intended to fit into a polarized outlet only one way. If the plug does not fit fully into the outlet, reverse the plug. If it still does not fit, contact a qualified electrician. Do not attempt to modify the plug in any way.**

Duotheek Plus

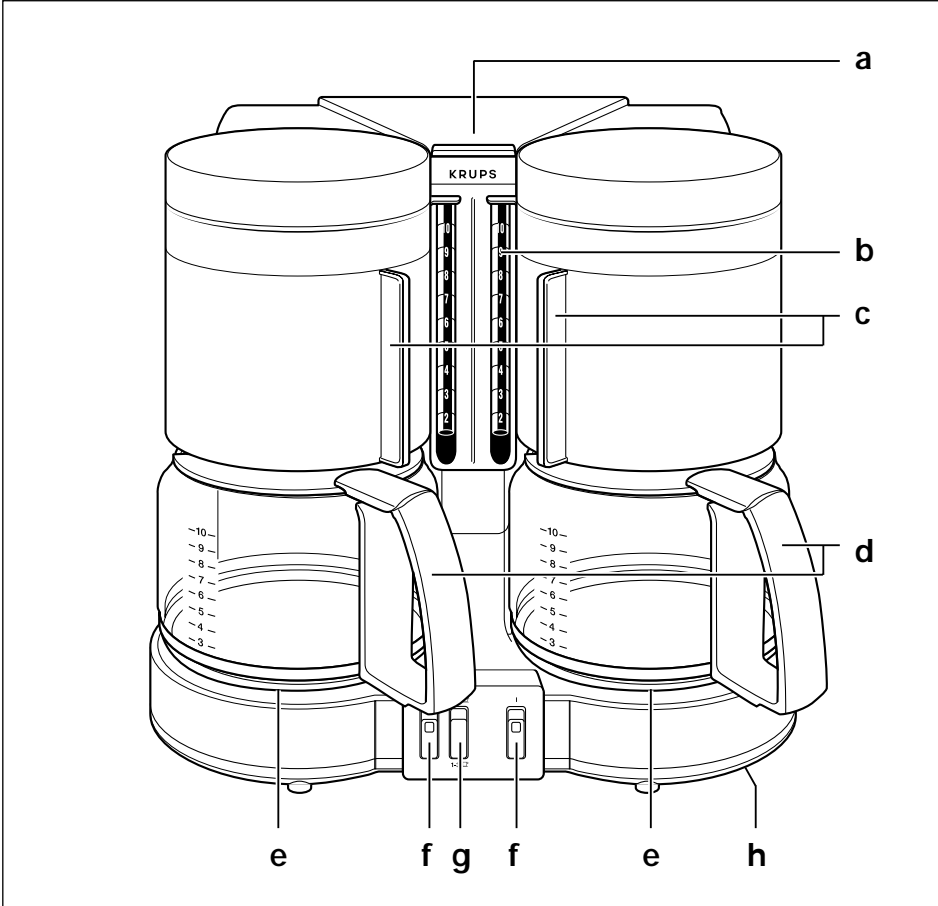

- a hinged water chamber lid
- b dual water level indicators
- c swing out filter holder
- d glass carafe

- e warming plate
- f illuminated on/off switch
- g full flavor selector switch (left side only)
- h hidden cord storage

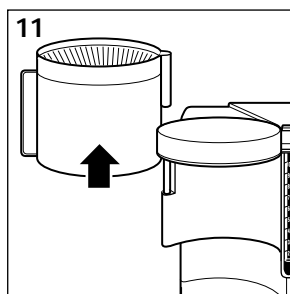
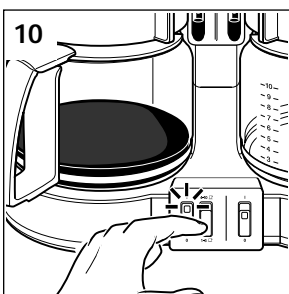
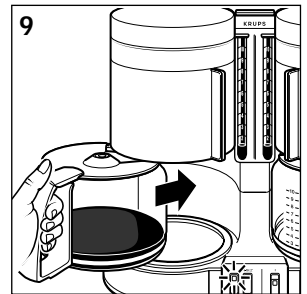
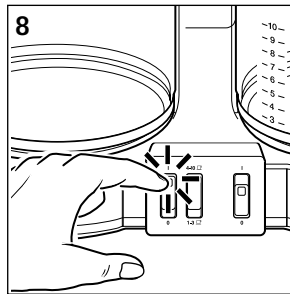
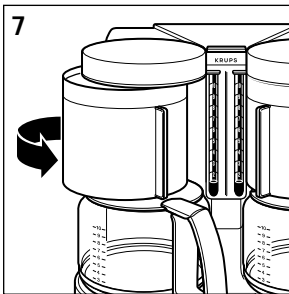
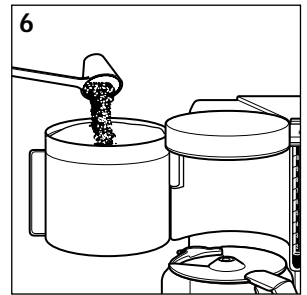
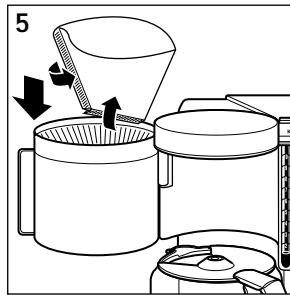
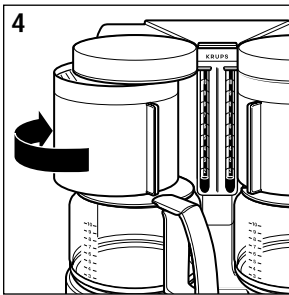
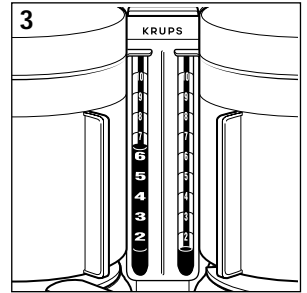
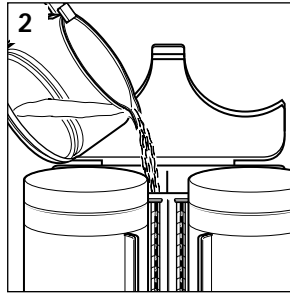
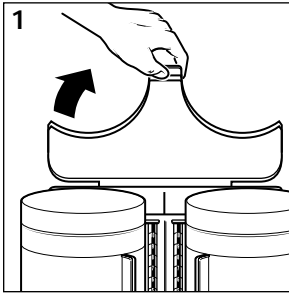

KRUPS „DuotheK Plus“ (model #464)

Your new DuotheK Plus coffee maker is a great new addition to your home or office, and is the perfect choice for entertaining. The DuotheK Plus has the following features:

- 2 x 10 cup dual coffeemaking system makes one or two pots simultaneously - perfect for entertaining!
- Exclusive KRUPS “Deep Brew” system with special filtering action for maximum flavor.
- Electronically controlled dual brewing cycle (left side only) slows down the brewing process when preparing less than 3 cups of coffee to ensure full bodied flavor even in small quantities.
- Swing out filter holders are convenient to use and easy to clean.
- “Stop ‘n Serve” feature lets you serve a cup or two while brewing. The automatic filter seal allows you to remove the carafe for 20 seconds without coffee dripping onto the warming plate.
- Automatic warming plate keeps coffee at the perfect drinking temperature; however, due to the breakdown of coffee’s aroma, we do not recommend serving coffee which has been kept warm more than one hour.
- Dual water level indicators easily let you measure how much water is in each water chamber.

- Hinged water chamber lid will protect the water chamber from dust and dirt.
- Krups specially designed heating and tubing system minimizes calcification and leaves no residual water in the system when brewing is finished.
- Hidden cord storage allows you to set the desired cord length.

Preparing coffee

Before making your first pot of delicious coffee, we recommend operating the coffee maker once or twice with water only, without ground coffee or a paper filter to remove any possible dust.

- Be sure that the water container is empty. Remove literature, etc. if inserted in the water container.
- The lid of the glass carafe must be properly positioned during the brewing process. Position the lid over the carafe and snap the rectangular piece onto the handle. The lid is then locked in place.
- Make sure that the swing away filter (e) is properly closed during the brewing process. When closing the swivel filter you will feel a noticeable resistance between the swivel filter and the base. Push in firmly until you hear the filter “click” into place.
- Caution: If the swivel filter is not completely closed, the “Stop ‘n Serve” trigger will not function properly, which may cause hot water or hot coffee to overflow.

- The “Stop ‘n Serve” mechanism is opened as long as the glass carafe is inserted into the machine and sits properly on the warming plate and the swivel filter is properly closed.

Filling the Water Chamber

Open the hinged lid (see figure 1).

Pour in the desired quantity of water (see figure 2).

The water level indicator shows you how much water you are filling into the container (see figure 3).

The amount of freshly brewed coffee delivered after the brewing process will always be slightly less than the amount put into the water container. This is due to the minimal absorption of the water by the ground coffee. Therefore, put in a little more water to begin with so that you will have the number of cups you desire.

Replace the carafe on the warming plate with the glass carafe lid in position.

Putting in the Ground Coffee

To open the swing away filter holder, move the filter handle to the left to swing the filter out (see figure 4).

Insert a paper filter (we recommend Krups size 4) with the seam pointing towards the handle of the filter holder (see figure 5).

Instead of filter paper you can also use the Krups goldtone filter (model #053). (When ordering filter paper or the goldtone filter from Krups be sure to indicate that they are for model #464.)

Put ground coffee into the paper filter (see figure 6). We suggest using one level Krups measuring spoon of ground coffee for each cup of robust brewed coffee.

After using your Krups coffee maker several times you can adjust the measure to suit your own taste.

Close the swivel filter and make sure that is completely closed (see figure 7).

You will feel a noticeable resistance between the swivel filter and the base. Push in firmly until you hear the filter “click” into place.

Attention!

Make sure that the filter paper does not tip over when closing the swivel filter, or else the water might run between the filter paper and the filter holder producing a very weak cup of coffee.

Plug in the coffeemaker and turn the on/off switch to the “on” position (right switch for right side, left switch for left side) (see figure 8).

Replace glass carafe on the warming plate with the lid securely in position (see figure 9).

Selecting the fullest flavor

The Krups “Duotheke” has a full flavor selector switch, if you want to make 1-3 cups of coffee, turn this switch to the appropriate position (see figure 10).

This will extend the brewing cycle so that the water will seep into the ground coffee slowly enough to yield brewed coffee that is rich, aromatic and truly delicious (works on left side only).

In order to have truly aromatic coffee, the water must be allowed to seep through the ground coffee for a certain minimum of time.

For making 4-12 cups, the full-flavor switch should be turned to the position “4-max”.

„Stop’n Serve“ Feature

The “Stop’n Serve” feature is KRUPS’ answer to the impatient coffee drinker’s clamor for “a quick cup of coffee!”. This device automatically stops the flow of brewed coffee through the filter cone of the glass carafe is removed from the warming plate during the brewing cycle. You have about 20 seconds between the removal of the carafe and its being reinserted to allow the serving of one or two cups of coffee.

The “Stop’n Serve” device closes off the filter cone so effectively that there is virtually no coffee-drip onto the warming plate (one drop, at most!).

Once the carafe is replaced, the brewing cycle and the flow of the coffee into the carafe are resumed.

Caution

If the coffee does drip onto the warming plate after removal of the carafe, it is usually an indication that the small black seal in the filter holder is missing or defective. It is also possible that too much ground coffee has been placed into the paper filter. This causes the water that jets into the filter cone to overflow between the paper filter and the sides of the filter cone.

The overflow carries the coffee grounds with it that interfere with the snap-shot action of the filter holder, thus allowing brewed coffee to continue to drip through.

If this blockage and subsequent dripping do occur, replace the glass carafe immediately and allow the full brewing cycle to run its course. Do not swing out the swivel filter until the brewing cycle is completed.

Cleaning

- Always unplug this appliance before cleaning. Remove the filter holder by opening the holder and lifting the filter directly off (see figure 11).
- Clean the filter holder, the carafe and carafe lid in a solution of hot water and mild liquid soap. These parts can also be placed in the upper level of your dishwasher for safe effective cleaning.

- Never use scouring agents.
- Never immerse the appliance itself in the water or any other liquid. To clean, simply wipe off with a soft, damp cloth.
- Never use a cloth to clean the inside of the water chamber, as this might leave fuzzy deposits in the chamber. Just rinse with cold water, periodically.

Decalcifying

Although your KRUPS coffee maker has the most advanced water heating and pumping system, it will periodically need cleaning with a decalcifying agent.

- This is due to the calcium (limestone) found in drinking water.
- In some areas where the water is hard, you will need to decalcify more frequently than in areas with soft water.
- It will also depend upon how often you use your coffee maker.

For best results.....

.....always use fresh , cold water (warm water might be stale and have mineral deposits which would impair the flavor of the coffee).

.....we recommend that you grind your own beans. Freshly ground beans deliver more aroma and flavor. Use one KRUPS measuring spoon of beans per cup.

.....serve coffee immediately after brewing.

..... never reheat coffee.

When to decalcify

You will know when such a cleaning is necessary by an obvious slowdown in the brewing time of your coffee. This extended time indicates that there are calcium deposits in your coffee maker.

We recommend using a decalcifying agent for cleaning your KRUPS coffee maker. If used in accordance with the following instructions, it will prolong the life of your coffee maker.

Decalcifying agents can be found in department and gourmet specialty stores, or by calling KRUPS Consumer Service.

Limited One Year Warranty

Your KRUPS #464 is covered by the following warranty:

If from date of purchase within one year this KRUPS product fails to function because of defects in materials or workmanship, KRUPS North America will, at its option, repair or replace the unit with our charge, provided the owner has a proof of date of purchase.

This warranty will be void if malfunction was caused by damage to the product by accident, misuse, use on frequency or voltage other than marked on the product and/or described in the instructions, abuse including tampering, damage in transit, or use for commercial purposes. This warranty gives you specific legal rights, and you may also have other rights which may vary from state to state.

GUARANTEE OF PERFORMANCE

This fine KRUPS product is manufactured according to a rigid code of quality standards, and, with minimum care, should give years of satisfying service. However, should the need arise for repairs or for replacement parts within or after the warranty period, please call our CONSUMER SERVICE DEPARTMENT:

(800) 526-5377
24-hours a day, 7 days a week

You will be provided with specific instruction on how to get your product repaired, as well as the name and address of your nearest authorized KRUPS Service Center. The department will also be able to answer any general product questions you may have.

Before calling the Consumer Service Department, please have the type number of your KRUPS appliance available. You must have this information before calling our Consumer Service Department so that we may better answer your questions. The type number can be located by looking at the bottom of your appliance.

This product is Type #464

Any general correspondence can be addressed to:

KRUPS North America, Inc.
P.O. Box 3900
Peoria, IL 61612